

STIHL[®]

STIHL FS 55

Instruction Manual



Contents

Guide to Using this Manual	2	Maintenance and Repairs	38
Safety Precautions and Working Techniques	2	Disposal	38
Approved Combinations of Cutting Attachment, Deflector, Handle and Harness	11	EC Declaration of Conformity	38
Mounting the Bike Handle	12	Quality Certification	39
Mounting the Loop Handle	13		
Fitting the Carrying Ring	15		
Mounting the Deflector	15		
Mounting the Cutting Attachment	16		
Fuel	19		
Fueling	20		
Fitting the Harness	20		
Balancing the Trimmer/Brushcutter	21		
Starting / Stopping the Engine	22		
Operating Instructions	25		
Cleaning the Air Filter	26		
Adjusting the Carburetor	26		
Spark Plug	29		
Engine Running Behavior	30		
Rewind Starter	30		
Lubricating the Gearbox	30		
Storing the Machine	31		
Sharpening Metal Cutting Blades	31		
Inspections and Maintenance by Dealer	31		
Maintenance and Care	32		
Minimize Wear and Avoid Damage	34		
Main Parts	35		
Specifications	36		
Special Accessories	37		

Dear Customer,

Thank you for choosing a quality engineered STIHL product.

It has been built using modern production techniques and comprehensive quality assurance. Every effort has been made to ensure your satisfaction and troublefree use of the product.

Please contact your dealer or our sales company if you have any queries concerning this product.

Your



Dr. Nikolas Stihl

STIHL®

FS 55, FS 55 C, FS 55 R, FS 55 RC

This instruction manual is protected by copyright. All rights reserved, especially the rights to reproduce, translate and process with electronic systems.

Guide to Using this Manual

Pictograms

The meanings of the pictograms attached to the machine are explained in this manual.

Depending on the model concerned, the following pictograms may be attached to your machine.



Fuel tank; fuel mixture of gasoline and engine oil

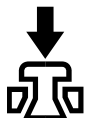

Operate decompression valve



Manual fuel pump

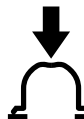

Operate manual fuel pump

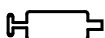

Tube of grease



Intake air: Summer operation



Intake air: Winter operation



Handle heating

Symbols in text



WARNING

Warning where there is a risk of an accident or personal injury or serious damage to property.



NOTICE

Caution where there is a risk of damaging the machine or its individual components.

Engineering improvements

STIHL's philosophy is to continually improve all of its products. For this reason we may modify the design, engineering and appearance of our products periodically.

Therefore, some changes, modifications and improvements may not be covered in this manual.

Safety Precautions and Working Techniques



Some special safety precautions must be observed to reduce the risk of personal injury when operating this power tool because of the very high speed of its cutting attachment.



It is important that you read the instruction manual before first use and keep it in a safe place for future reference. Non-observance of the instruction manual may result in serious or even fatal injury.



Observe all application local safety regulations, standards and ordinances.

If you have not used this type of power tool before: Have your dealer or other experienced user show you how to operate your unit or attend a special course in its operation.

Minors should never be allowed to use a power tool.

Keep bystanders, especially children, and animals away from the work area.

When the power tool is not in use, shut it off so that it does not endanger others. Secure it against unauthorized use.

The user is responsible for avoiding injury to third parties or damage to their property.

Do not lend or rent your power tool without the instruction manual. Be sure that anyone using it understands the information contained in this manual.

The use of noise emitting power tools may be restricted to certain times by national or local regulations.

To operate the power tool you must be rested, in good physical condition and mental health.

If you have any condition that might be aggravated by strenuous work, check with your doctor before operating a power tool.

Persons with pacemakers only: The ignition system of your power tool produces an electromagnetic field of a very low intensity. This field may interfere with some pacemakers. STIHL recommends that persons with pacemakers consult their physician and the pacemaker manufacturer to reduce any health risk.

Do not operate the power tool if you are under the influence of any substance (drugs, alcohol) which might impair vision, dexterity or judgment.

Depending on the cutting attachment fitted, use your power tool only for cutting grass, wild growth, shrubs, scrub, bushes, small diameter trees and similar materials.

Do not use your power tool for any other purpose because of the **increased risk of accidents**.

Only use cutting attachments and accessories that are explicitly approved for this power tool model by STIHL or are technically identical. If you have any questions in this respect, consult a

servicing dealer. Use only high quality parts and accessories in order to avoid the risk of accidents and damage to the machine.

STIHL recommends the use of original STIHL replacement parts. They are specifically designed to match the product and meet your performance requirements.

Never attempt to modify your unit in any way since this may increase the risk of personal injury. STIHL excludes all liability for personal injury and damage to property caused while using unauthorized attachments.

Do not use a pressure washer to clean the unit. The solid jet of water may damage parts of the unit.

The deflector on this power tool cannot protect the operator from all objects thrown by the cutting attachment (stones, glass, wire, etc.). Such objects may ricochet and then hit the operator.

Clothing and Equipment

Wear proper protective clothing and equipment.



Clothing must be sturdy but allow complete freedom of movement. Wear snug-fitting clothing, an overall and jacket combination, do not wear a work coat.



Avoid clothing that could get caught on branches or brush or moving parts of the machine. Do not wear a scarf, necktie or jewelry. Tie up and confine long hair (e.g. with a hair net, cap, hard hat, etc.).



Wear steel-toed safety boots with non-slip soles.

Sturdy shoes with non-slip soles may be worn as an alternative only when using mowing heads.



Wear a safety hard hat for thinning operations, when working in high scrub and where there is a danger of head injuries from falling objects. To reduce the risk of injury from thrown objects, always wear a face shield and safety glasses.

A face shield alone does not provide adequate eye protection.

Wear hearing protection, e.g. earplugs or ear muffs.



Wear heavy-duty gloves.

STIHL offers a comprehensive range of personal protective clothing and equipment.

Transporting the Power Tool

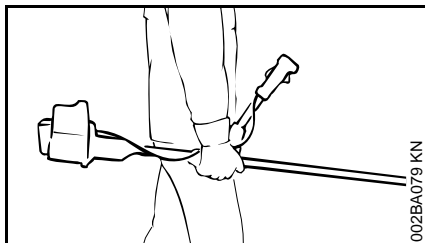
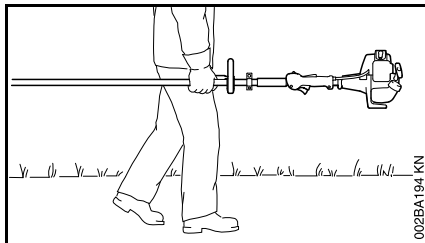

Always turn off the engine.

Carry the unit hanging from the shoulder strap or properly balanced by the drive tube. Fit transport guard on metal cutting attachments to avoid the risk of injury from blade contact

In vehicles: Properly secure your power tool to prevent turnover, fuel spillage and damage.

Fueling



Gasoline is an extremely flammable fuel. Keep clear of naked flames. Do not spill any fuel – do not smoke.

Always shut off the engine before refueling.

Do not fuel a hot engine – **fuel may spill and cause a fire.**

Open the fuel cap carefully to allow any pressure build-up in the tank to release slowly and avoid fuel spillage.

Fuel your power tool only in well-ventilated areas. If you spill fuel, wipe the machine immediately – if fuel gets on your clothing, change immediately.

Your power tool comes standard with either a screw-type or bayonet-type fuel cap.



After fueling, tighten down the screw-type fuel cap as securely as possible.



Insert the fuel cap with hinged grip (bayonet-type cap) correctly in the opening, turn it clockwise as far as stop and fold the grip down.

This reduces the risk of unit vibrations causing the fuel cap to loosen or come off and spill quantities of fuel.

To reduce the risk of serious or fatal burn injuries, check for fuel leakage. If fuel leakage is found, do not start or run the engine until leak is fixed.

Before Starting

Check that your power tool is properly assembled and in good condition – refer to appropriate chapters in the instruction manual.

- Use only an approved combination of cutting attachment, deflector, handle and harness. All parts must be assembled properly and securely.
- Slide control / stop switch must move easily to **STOP** or **0**.
- Smooth action of throttle trigger lockout (if fitted) and throttle trigger – the throttle trigger must return automatically to the idle position.
- Check that the spark plug boot is secure – a loose boot may cause arcing that could ignite combustible fumes **and cause a fire**.
- Check cutting tool or attachment for correct and secure assembly and good condition.
- Check protective devices (e.g. deflector for cutting attachment, rider plate) for damage or wear. Always replace damaged parts. Do not operate your machine with a damaged deflector or worn rider plate (lettering and arrows no longer legible).
- Never attempt to modify the controls or safety devices in any way.

- Keep the handles dry and clean – free from oil and dirt – for safe control of the power tool.
- Adjust the harness and handle(s) to suit your height and reach. See chapters on "Fitting the Harness" and "Balancing the Trimmer/Brushcutter".

To reduce the risk of personal injury, do not operate your power tool if it is damaged or not properly assembled.

If you use a shoulder strap or full harness: Practice removing and putting down the power tool as you would in an emergency. To avoid damage, do not throw the power tool to the ground when practicing.

Start the engine.

Start the engine at least 3 meters from the fueling spot, outdoors only.

Place the unit on firm ground in an open area. Make sure you have good balance and secure footing. Hold the unit securely. The cutting attachment must be clear of the ground and all other obstructions because it may begin to run when the engine starts.

Your power tool is a one-person unit. **To reduce the risk of injury** from thrown objects, do not allow other persons within a radius of 15 meters of your own position – even when starting.



To reduce the risk of injury, avoid contact with the cutting attachment.



Do not drop start the power tool – start the engine as described in the instruction manual. Note that the cutting attachment continues to run for a short period after you let go of the throttle trigger – **flywheel effect**.

Check idle speed setting: The cutting attachment must not rotate when the engine is idling with the throttle trigger released.

To reduce the risk of fire, keep hot exhaust gases and hot muffler away from easily combustible materials (e.g. wood chips, bark, dry grass, fuel).

Holding and Controlling the Unit

Always hold the power tool firmly with both hands on the handles.

Make sure you always have good balance and secure footing.

Models with bike handle

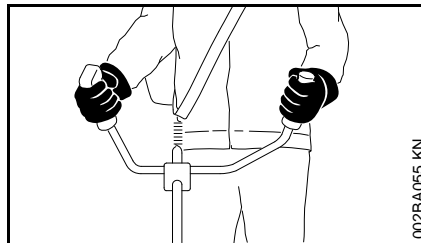

Right handle on control handle, left hand on left handle.

Models with loop handle

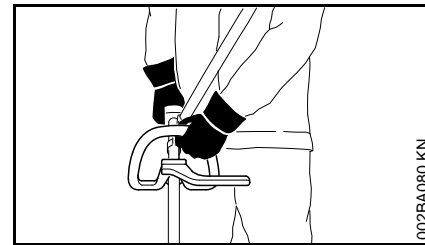

On models with a loop handle and barrier bar, left hand on loop handle, right hand on control handle, even if you are left-handed.

During Operation

Make sure you always have good balance and secure footing.

In the event of impending danger or in an emergency, switch off the engine immediately by moving the slide control / stop switch to **STOP** or **0**.

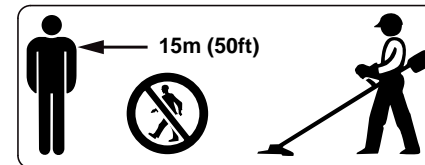

The cutting attachment may catch and fling objects a great distance and cause injury - therefore, do not allow any other persons within a radius of 15 meters of your own position. **To reduce the risk of damage to property**, also maintain this distance from other objects (vehicles, windows). Even maintaining a distance of 15 meters or more cannot exclude the potential danger.

The correct engine idle speed is important to ensure that the cutting attachment stops rotating when you let go of the throttle trigger.

Check and correct the idle speed setting regularly. If the cutting attachment continues to rotate when the engine is idling, have the machine checked by your servicing dealer. STIHL recommends a STIHL servicing dealer.

Take special care in slippery conditions, on slopes or uneven ground.

Watch out for obstacles: Roots, tree stumps or holes which **could cause you to trip or stumble.**

Always stand on the ground while working, never on a ladder, work platform or any other insecure support.

Be particularly alert and cautious when wearing hearing protection because your ability to hear warnings (shouts, alarms, etc.) is restricted.

To reduce the risk of accidents, take a break in good time to avoid tiredness or exhaustion.

Work calmly and carefully – in daylight conditions and only when visibility is good. Stay alert so as not to endanger others.



Your power tool produces toxic exhaust fumes as soon as the engine is running. These fumes may be colorless and odorless and contain unburned hydrocarbons and benzol. Never run the engine indoors or in poorly ventilated locations, even if your model is equipped with a catalytic converter.

To reduce the risk of serious or fatal injury from breathing toxic fumes, ensure proper ventilation when working in trenches, hollows or other confined locations.

To reduce the risk of accidents, stop work immediately in the event of nausea, headache, visual disturbances (e.g. reduced field of vision), problems with hearing, dizziness, deterioration in ability to concentrate. Apart from other possibilities, these symptoms may be caused by an excessively high concentration of exhaust gases in the work area.

Operate your power tool so that it produces a minimum of noise and emissions – do not run the engine unnecessarily, accelerate the engine only when working.

To reduce the risk of fire, do not smoke while operating or standing near your power tool. Note that combustible fuel vapor may escape from the fuel system.

The dusts, vapor and smoke produced during operation may be dangerous to health. If the work area is very dusty or smoky, wear a respirator.

If your power tool is subjected to unusually high loads for which it was not designed (e.g. heavy impact or a fall), always check that it is in good condition before continuing work – see also "Before Starting".

Check the fuel system in particular for leaks and make sure the safety devices are working properly. Do not continue operating your power tool if it is damaged. In case of doubt, have the unit checked by your servicing dealer.

Do not operate your power tool in the starting throttle position – engine speed cannot be controlled in this position.



To reduce the risk of injury from thrown objects, never operate the unit without the proper deflector for the type of cutting attachment being used.



Inspect the work area: Stones, pieces of metal or other solid objects may be thrown more than 15 meters and **cause personal injury** or damage the cutting attachment and property (e.g. parked vehicles, windows).

Special care must be taken when working in difficult, over-grown terrain.

When cutting high scrub, under bushes and hedges: Keep cutting attachment at a minimum height of 15 cm to avoid harming small animals.

Always shut off the engine before leaving the unit unattended.

Check the cutting attachment at regular short intervals during operation or immediately if there is a noticeable change in cutting behavior:

- Turn off the engine. Hold the unit firmly and wait for the cutting attachment to come to a standstill.
- Check condition and tightness, look for cracks.
- Check sharpness.
- Replace damaged or dull cutting attachments immediately, even if they have only superficial cracks.

Clean grass and plant residue off the cutting attachment mounting at regular intervals – remove any build up of material from the cutting attachment and deflector.

To **reduce the risk of injury**, shut off the engine before replacing the cutting attachment.

Do not continue using or attempt to repair damaged or cracked cutting attachments by welding, straightening or modifying the shape (out of balance).

This may cause parts of the cutting attachment to come off and hit the operator or bystanders at high speed and **result in serious or fatal injuries**.

When using mowing heads

Equip the deflector with the additional components specified in the instruction manual.

Use only the deflector with properly mounted line limiting blade to ensure the mowing lines are automatically trimmed to the approved length.

To **reduce the risk of injury**, always turn off the engine before adjusting the nylon line of manually adjustable mowing heads

Using the unit with over-long nylon cutting lines reduces the motor's operating speed. The clutch then slips continuously and this causes overheating and damage to important components (e.g. clutch, polymer housing components) – **and this can increase the risk of injury** from the cutting attachment rotating while the engine is idling.

Using metal cutting attachments

STIHL recommends the use of original STIHL metal cutting attachments. They are specifically designed to match your model and meet your performance requirements.

Metal cutting attachments rotate at very high speed. The forces that occur act on the machine, the attachment and the material being cut.

Sharpen metal cutting attachments regularly as specified.

Unevenly sharpened metal cutting attachments cause out-of-balance which can impose extremely high loads on the machine and increase the **risk of breakage**.

Dull or improperly sharpened cutting edges can put a higher load on the cutting attachment and increase the **risk of injury** from cracked or broken parts.

Inspect metal cutting attachments for cracks or warping after every contact with hard objects (e.g. stones, rocks, pieces of metal). To **reduce the risk of injury**, remove burrs and other visible build-ups of material (use a file) because they may become detached and be thrown at high speed during operation.

To reduce the above-mentioned risks when using a metal cutting attachment, never use a metal cutting attachment with a diameter larger than specified. It must not be too heavy. It must be manufactured from materials of adequate quality and its geometry must be correct (shape, thickness).

To **reduce the risk of injury**, a metal cutting attachment not manufactured by STIHL must not be heavier, thicker, have a different shape or a diameter larger than the largest metal cutting attachment approved by STIHL for this power tool model.

Vibrations

Prolonged use of the power tool may result in vibration-induced circulation problems in the hands (whitefinger disease).

No general recommendation can be given for the length of usage because it depends on several factors.

The period of usage is prolonged by:

- Hand protection (wearing warm gloves)
- Work breaks

The period of usage is shortened by:

- Any personal tendency to suffer from poor circulation (symptoms: frequently cold fingers, tingling sensations).
- Low outside temperatures.
- The force with which the handles are held (a tight grip restricts circulation).

Continual and regular users should monitor closely the condition of their hands and fingers. If any of the above symptoms appear (e.g. tingling sensation in fingers), seek medical advice.

Maintenance and Repairs

Service the machine regularly. Do not attempt any maintenance or repair work not described in the instruction manual. Have all other work performed by a servicing dealer.

STIHL recommends that you have servicing and repair work carried out exclusively by an authorized STIHL servicing dealer. STIHL dealers are regularly given the opportunity to attend training courses and are supplied with the necessary technical information.

Only use high-quality replacement parts in order to avoid the risk of accidents and damage to the machine. If you have any questions in this respect, consult a servicing dealer.

STIHL recommends the use of original STIHL replacement parts. They are specifically designed to match your model and meet your performance requirements.

To reduce the risk of injury, **always shut off the engine** before carrying out any maintenance or repairs or cleaning the machine. – Exception: Carburetor and idle speed adjustments.

Do not turn the engine over on the starter with the spark plug boot or spark plug removed unless the slide control / stop switch is on **STOP** or **0** since there is otherwise a **risk of fire** from uncontained sparking.

To reduce the **risk of fire**, do not service or store your machine near open flames.

Check the fuel filler cap for leaks at regular intervals.

Use only a spark plug of the type approved by STIHL and make sure it is in good condition – see "Specifications".

Inspect the ignition lead (insulation in good condition, secure connection).

Check the condition of the muffler.

To reduce the **risk of fire and damage to hearing**, do not operate your machine if the muffler is damaged or missing. –

Do not touch a hot muffler since **burn injury** will result.

Symbols on Deflectors

An arrow on the deflector shows the correct direction of rotation of the cutting attachments.



Use deflector in combination with mowing heads only. Do not use metal cutting attachments.

Shoulder strap

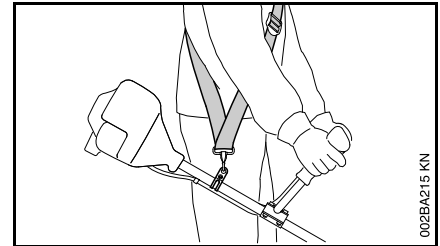

- Use a shoulder strap.
- With the engine running, attach the machine to the shoulder strap.

Grass cutting blades must always be used in combination with a shoulder strap.

Mowing Head with Nylon Line

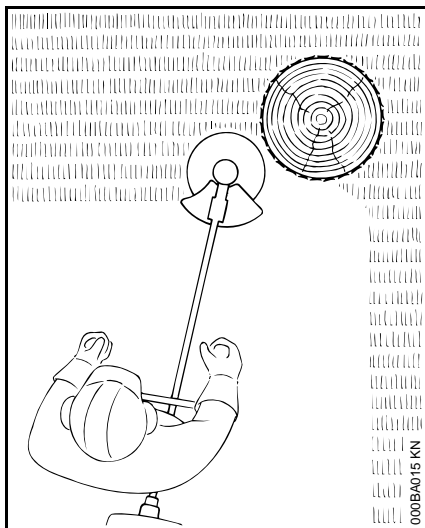

Nylon line achieves a soft cut for edging and trimming around trees, fence posts, etc. – less risk of damaging tree bark.

The mowing head comes with an instruction leaflet. Refill the mowing head with nylon line as described in the instruction leaflet.

! WARNING

To reduce the risk of serious injury, never use wire or metal-reinforced line in place of the nylon line.

STIHL FixCut

Check the wear limit marks!

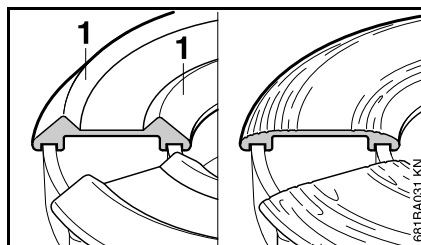

- If the raised moldings (1) on the base of the attachment are worn as shown in the illustration (above right), do not continue using the mowing head. Install a new one. There is otherwise a **risk of injury** from thrown parts of the head.

STIHL Polycut Mowing Head with Polymer Blades

For mowing unobstructed edges of meadows (without posts, fences, trees or similar obstacles).

Check the wear limit marks!

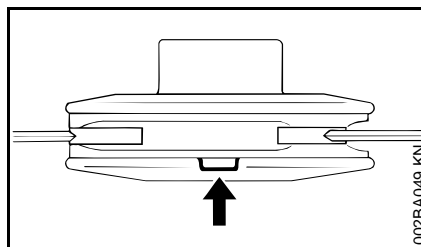

If one of the wear limit marks on the Polycut mowing head is worn through (arrow): Do not continue using the mowing head. Install a new one. There is otherwise a **risk of injury** from thrown parts of the head.

It is important to follow the maintenance instructions for the PolyCut mowing head.

The PolyCut can also be equipped with mowing line in place of the polymer blades.

The mowing head comes with instruction leaflets. Equip the mowing head with polymers blades or nylon line as described in the instruction leaflets.

! WARNING

Never use wire in place of the nylon mowing line – **risk of injury**.

Risk of Kickout (Blade Thrust) with Metal Cutting Blades

When using grass cutting blades there is a risk of kickout when the rotating blade comes into contact with a solid object like a tree trunk, branch, tree stump, rock or similar. The machine is thrown to the right or to the rear – opposite to the blade's direction of rotation.

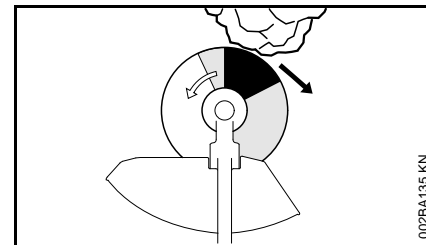

The risk of kickout is greatest when the black area of the rotating blade comes into contact with a solid object.

Grass Cutting Blade

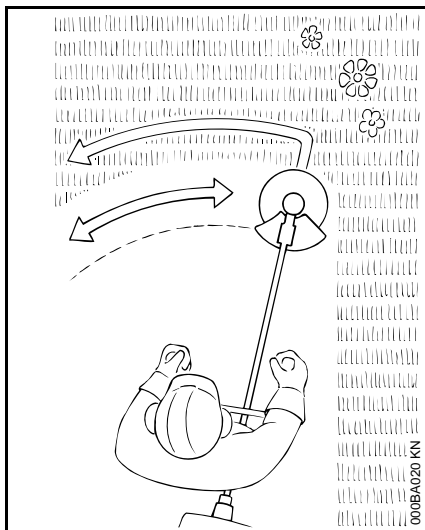

Use for grass and weeds only – sweep the brushcutter in an arc like a scythe.

WARNING

Improper use may damage the grass cutting blade – **risk of injury** from thrown parts.

Resharpener the grass cutting blade according to instructions when it has dulled noticeably.

Approved Combinations of Cutting Attachment, Deflector, Handle and Harness

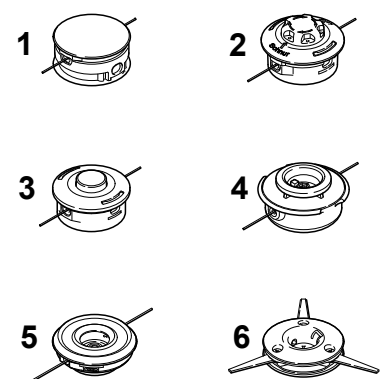
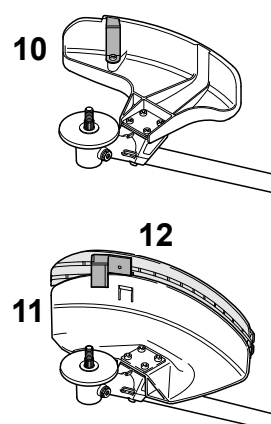
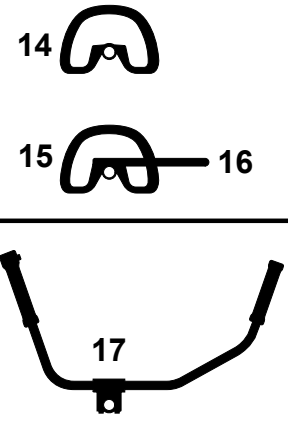
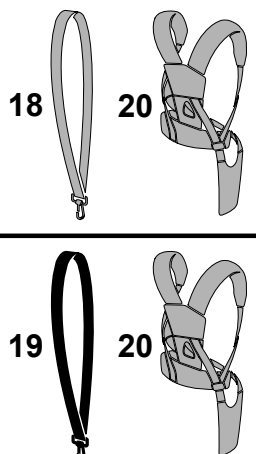
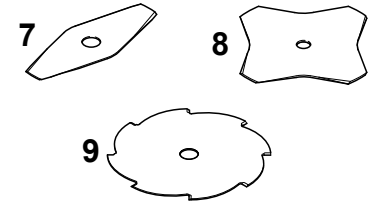
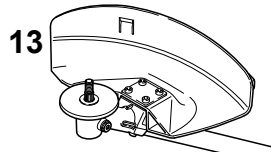
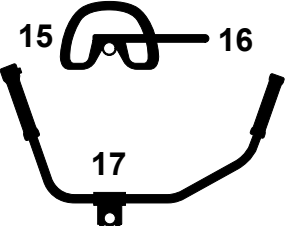
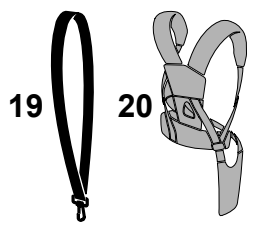
Cutting Attachment	Deflector	Handle	Harness / Shoulder Strap
 <p>1 2 3 4 5 6</p>	 <p>10 11 12</p>	 <p>14 15 16 17</p>	 <p>18 20 19 20</p>
 <p>7 8 9</p>	 <p>13</p>	 <p>15 16 17</p>	 <p>19 20</p>

681BA120 KN

Approved Combinations

Select correct combination from the table according to the cutting attachment you intend to use.

WARNING

For safety reasons only the cutting attachments, deflectors, handles and harnesses/shoulder straps shown in each row of the table may be used together. No other combinations are permitted because of the **risk of accidents**.

Cutting Attachments

Mowing heads

- 1 STIHL SuperCut 20-2
- 2 STIHL AutoCut C 25--2
- 3 STIHL AutoCut 25-2
- 4 STIHL TrimCut 31-2
- 5 STIHL FixCut 25-2

6 STIHL PolyCut 20-3

Metal mowing attachments

7 Grass cutting blade 230-2

8 Grass cutting blade 230-4

9 Grass cutting blade 230-8

! WARNING

Non-metal grass cutting blades are not approved.

Deflectors

10 Deflector **only** for mowing heads

11 Deflector **with**

12 Skirt and blade for all mowing heads

13 Deflector **without** skirt and blade for all metal mowing attachments

Handles

14 Loop handle

15 Loop handle **with**

16 Barrier bar

17 Bike handle

Harnesses

18 Shoulder strap may be used

19 Shoulder strap must be used

20 Full harness may be used

Mounting the Bike Handle

Mounting the handlebar

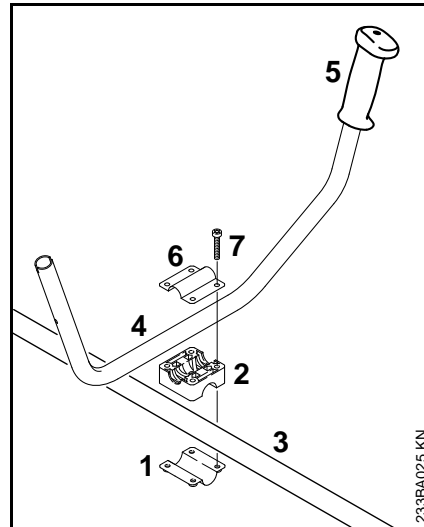

- Position the clamp (1) and handlebar support (2) on the shaft (3)
- Place the handlebar (4) in the handlebar support – the rubber handle (5) must be on the left (viewing direction from engine to handlebar)
- Place the clamp (6) on the handlebar support
- Insert screws (7) through the holes in the parts and screw them into the clamp (6) as far as they will go

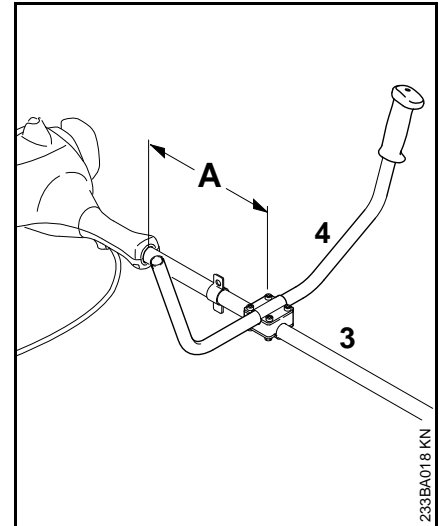

- Fasten handlebar (4) at a distance (A) of approx. 15 cm (6 in) ahead of the engine housing on the shaft (3)
- Align the handlebar and tighten the screws

Attaching the control handle

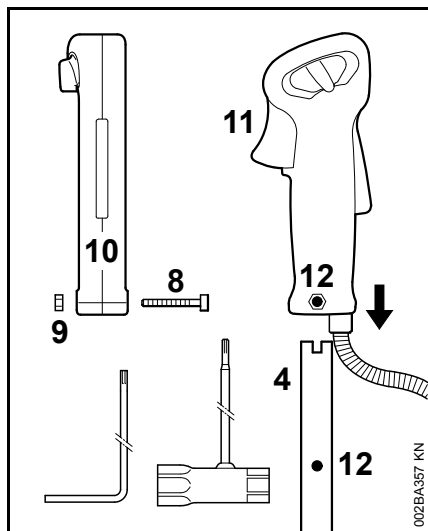

- Unscrew bolt (8) with a combination wrench or hex key wrench – the nut (9) remains in the control handle (10)
- Push the control handle with the throttle trigger (11) facing toward the gearbox onto the handlebar (4) until the holes (12) align
- Screw in the bolt (8) and tighten up

Fasten the throttle cable



NOTICE

Do not kink the throttle cable or run it in tight radiuses – the throttle trigger must move freely!

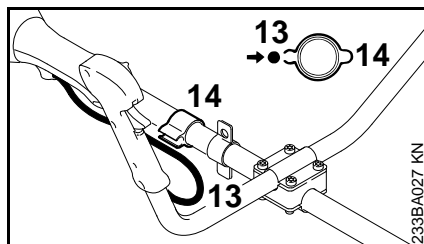

- Press throttle cable (13) into the throttle cable support (14)

Mounting the Loop Handle

Loop handle with barrier bar

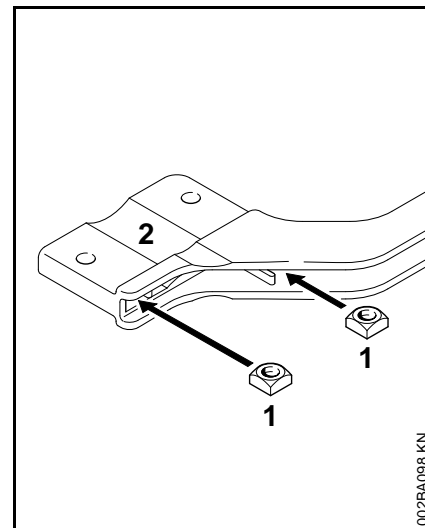

- Fit the square nuts (1) in the barrier bar (2); the holes must line up.

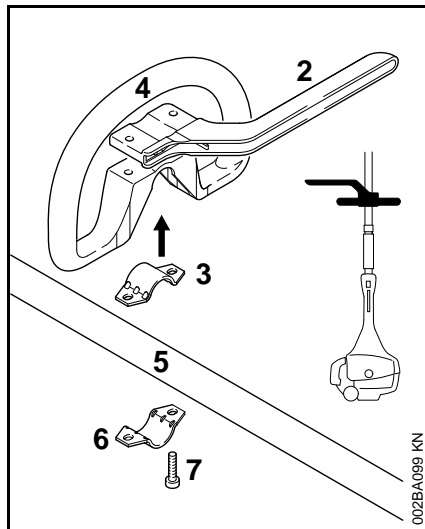

- Fit the clamp (3) in the loop handle (4) and place them both on the drive tube (5).
- Place the clamp (6) in position.
- Place the barrier bar (2) in position as shown.
- Line up the holes.
- Insert the screws (7) and tighten them down moderately against the barrier bar.
- Go to "Securing the loop handle".

Loop handle without barrier bar

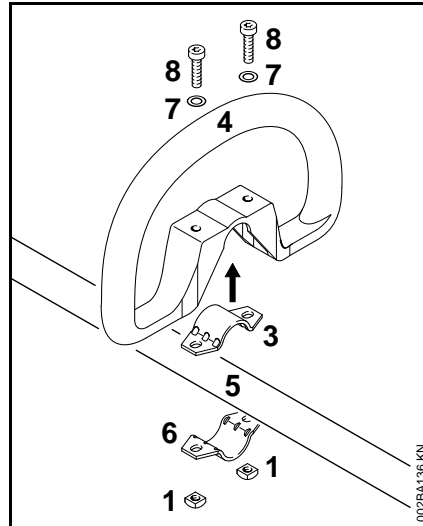

- Fit the clamp (3) in the loop handle (4) and place them both on the drive tube (5).
- Place the clamp (6) in position.
- Line up the holes.
- Fit washers (7) on the screws (8) and insert the screws in the holes. Fit the square nuts (1) and screw them down as far as stop.
- Go to "Securing the loop handle".

Securing the loop handle

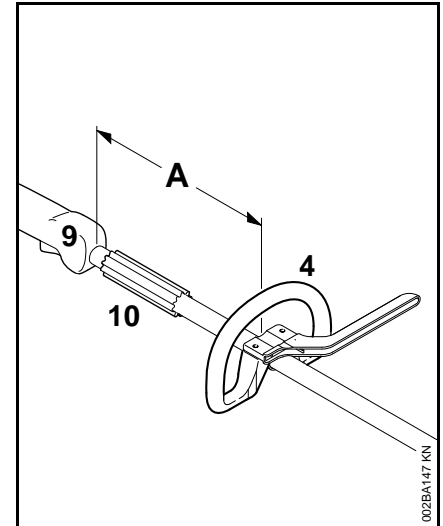

- Secure the loop handle (4) about 20cm/8in (A) forward of the control handle (9).
- Line up the loop handle.
- Tighten down the screws firmly – lock the nuts if necessary.

The sleeve (10) (not fitted on all models) must be between the loop handle and the control handle.

Fitting the Carrying Ring

The carrying ring comes standard with the machine or is available as a special accessory.

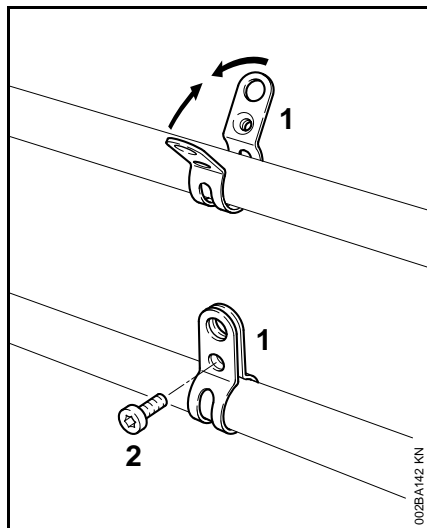

For position of carrying ring see "Main Parts".

- Place the clamp (1) against the drive tube **with the tapped hole on the left** (viewed from engine).
- Squeeze the two ends of the clamp together and hold in that position.
- Insert the M6x14 screw (2).
- Line up the carrying ring.
- Tighten down the screw firmly.

Mounting the Deflector

Mounting the Deflector

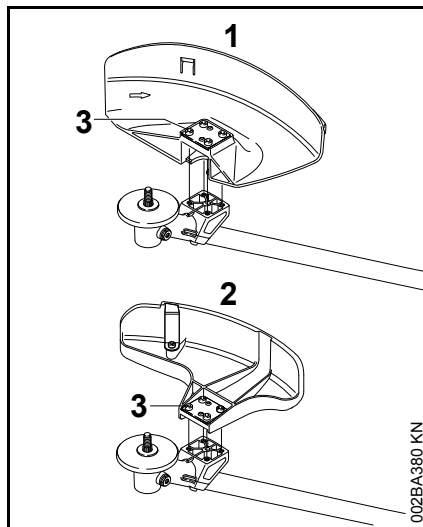

- 1 Deflector for mowing attachments
- 2 Deflector for mowing heads

Deflectors (1) and (2) are both mounted to the gearbox in the same way.

- Place the deflector on the gearbox flange.
- Insert the screws (3) and tighten them down firmly.

Fitting the Skirt and Blade

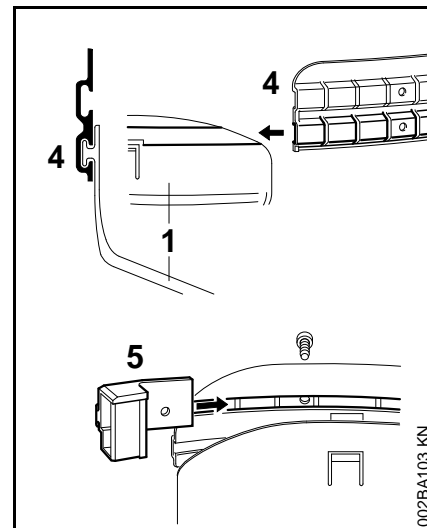

! WARNING

These parts must be fitted to the deflector (1) when you use a mowing head.

- Slide the lower guide slot of the skirt (4) onto the deflector (1) – it must snap into position.
- Push the blade (5) into the upper guide slot on the skirt and line it up with the first hole.
- Insert the screw and tighten it down firmly.

Mounting the Cutting Attachment

Preparations

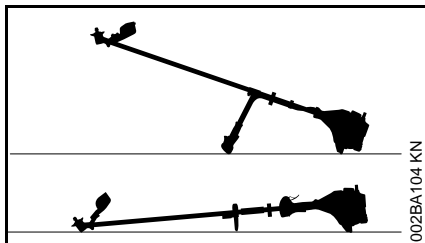

- Lay your brushcutter on its back so that the cutting attachment mounting face is facing up.

Mounting hardware for cutting attachments

The mounting hardware supplied depends on the cutting attachment that comes as original equipment with the new machine.

Mounting hardware is not packed with machine

Only mowing heads can be mounted.

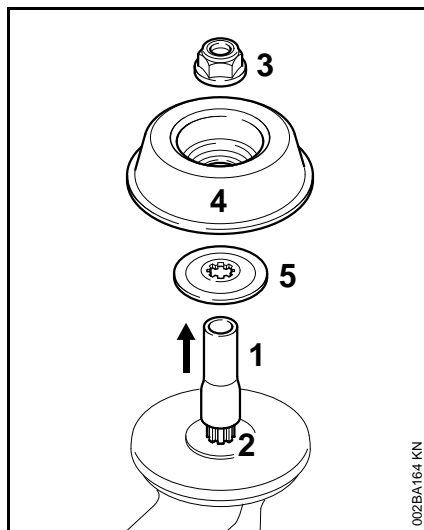

- Pull the hose (1) (protector for shipping) off the shaft (2).
- Go to "Mounting the mowing head".

If you want to mount a metal cutting attachment in place of a mowing head, you will need the following additional parts: Nut (3), rider plate (4) and thrust washer (5) (special accessories).

Mounting hardware is packed with machine

Mowing heads and metal cutting attachments may be mounted.

If the parts are packed with the machine

- Pull the hose (1) (protector for shipping) off the shaft (2).

The nut (3), rider plate (4) and thrust washer (5) are in the parts kit supplied with the machine.

- Go to "Mounting the mowing head" or "Mounting the metal cutting attachment".

If the parts are mounted to the gearbox

- Go to "Removing the mounting hardware".

Removing the mounting hardware

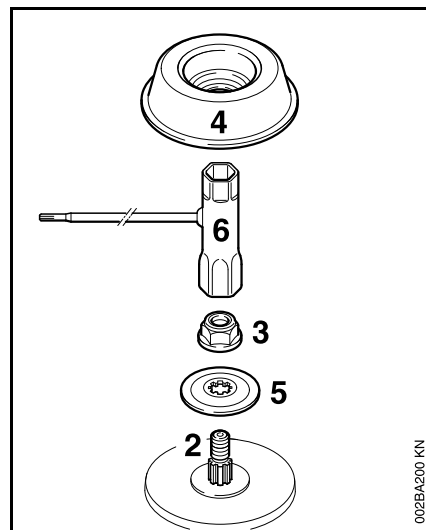

- Block the shaft – see next chapter on "Blocking the output shaft".
- Use the combination wrench (6) – comes standard with machine or is available as special accessory – to unscrew the nut (3) clockwise (left-hand thread) from the shaft (2).
- Pull the thrust washer (5) off the shaft (2).

The rider plate (4) is in the parts kit supplied with the machine.

- Go to "Mounting the mowing head" or "Mounting the metal cutting attachment".

Blocking the output shaft

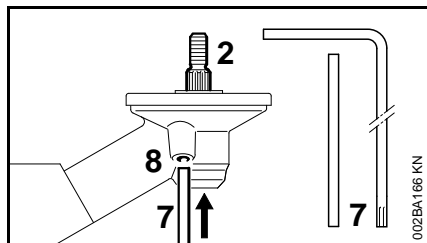

- Insert the stop pin (7) or screwdriver – come standard with machine or are available as special accessories – in the hole (8) in the gearbox as far as stop, and apply slight pressure.
- Rotate the nut or cutting attachment on the shaft (2) until the stop pin slips into position and blocks the shaft.

Mounting the mowing head

Keep the instruction leaflet for the mowing head in a safe place.

STIHL SuperCut 20-2
STIHL AutoCut 25-2,
STIHL AutoCut C 25-2,

STIHL TrimCut 31-2,
STIHL FixCut 25-2,
STIHL PolyCut 20-3

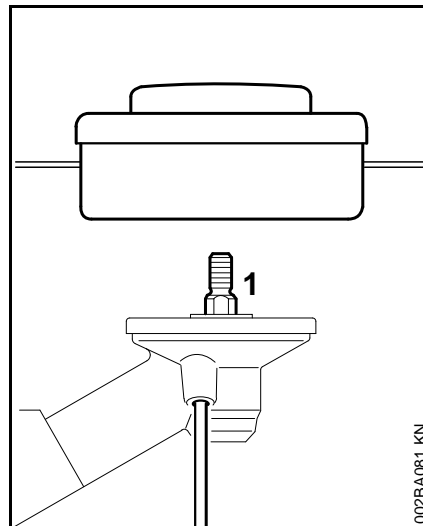

- Screw the mowing head counterclockwise on to the shaft (1) as far as stop.
- Block the drive shaft.
- Tighten down the mowing head.



Remove the tool used to block the shaft.

Removing the mowing head

- Block the drive shaft.

STIHL SuperCut 20-2,
STIHL AutoCut 25-2,
STIHL AutoCut C 25-2,

STIHL TrimCut 31-2,
STIHL FixCut 25-2,
STIHL PolyCut 20-3

- Unscrew the mowing head clockwise.

Adjusting nylon line

STIHL SuperCut

Fresh line is advanced automatically if remaining line is still at least **6 cm** long. The blade on the deflector trims surplus line to the correct length.

STIHL AutoCut

- Hold the rotating mowing head above the ground – tap it on the ground once – about **3 cm** fresh line is advanced.

The blade on the deflector trims surplus line to the correct length – avoid tapping the mowing head more than once at a time.

Line feed operates only if **both** mowing lines still have a minimum length of **2.5 cm**.

All other mowing heads

Refer to the instructions supplied with the mowing head.



To reduce the risk of injury, always shut off the engine before adjusting the mowing line by hand.

Replacing Nylon Line or Cutting Blades

Refer to the instructions supplied with the mowing head.

Mounting Metal Cutting Attachments

! WARNING

Wear protective gloves to reduce the risk of direct contact with the sharp cutting edges.

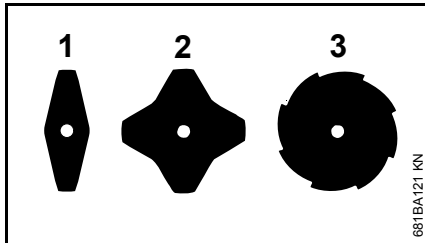

The **skirt and line limiting blade** are not required on the deflector for grass cutting blades 230-2 (1), 230-4 (2) or 230-8 (3) – see "Mounting the Deflector".

⚙ NOTICE

Use the optional special thrust plate (5, next illustration) for metal cutting attachments – have your servicing dealer check the machine if necessary.

If your new brushcutter came equipped with a metal cutting attachment, the correct thrust plate (5) will already be mounted.

- Put your brushcutter on the ground – cutting attachment mounting face must point up.

Cutting edges of grass cutting blades (1) and (2) may point in either direction.

Cutting edges of grass cutting blade (3) must point clockwise.

! WARNING

Direction of rotation is indicated by an arrow on the inside of the deflector.

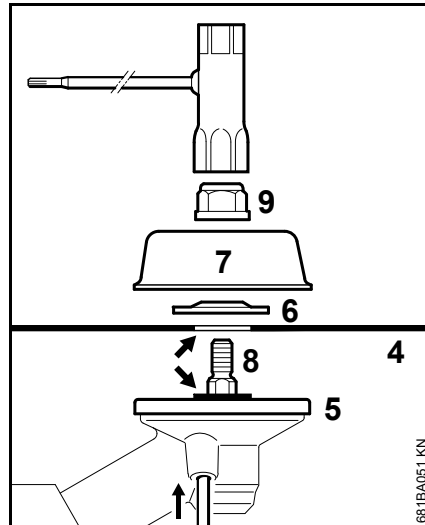

- Place the cutting attachment (4) on the thrust plate (5).

! WARNING

Collar (see arrow) must engage the cutting attachment's mounting hole.

- Fit the thrust washer (6) and rider plate (7) on the shaft (8).
- Block the shaft.
- Screw the mounting nut (9) on to the shaft counterclockwise and tighten it down firmly.

! WARNING

If the mounting nut has become too loose, fit a new one.

Removing Metal Cutting Attachments

! WARNING

Wear protective gloves to reduce the risk of direct contact with the sharp cutting edges.

- Block the shaft.
- Unscrew the mounting nut clockwise.
- Take the parts off the shaft – **do not** remove the thrust plate (5).

Fuel

The engine requires a mixture of gasoline and engine oil.

WARNING

Avoid direct skin contact with and breathing in of gasoline fumes.

STIHL MotoMix

STIHL recommends using STIHL MotoMix. This pre-blended fuel is free of benzene and lead, stands out because of a high octane rating, and always provides the proper mixing ratio.

STIHL MotoMix is blended with STIHL HP Ultra two-stroke engine oil for maximum engine life.

MotoMix is not available in all markets.

Mixing fuel

NOTICE

Unsuitable fuels or a mixing ratio that deviates from the specification can lead to severe engine damage. The engine, seals, fuel lines and fuel tank may be damaged if poor quality gasoline or engine oil is used.

Gasoline

Use only **high-quality gasoline** with an octane rating of at least 90 ROC – leaded or unleaded.

Unleaded gasoline must be used in machines equipped with a catalytic converter.

NOTICE

Using multiple tankfuls of leaded gasoline can substantially reduce the effectiveness of the catalytic converter.

Gasoline with an alcohol component exceeding 10% can cause impaired engine performance in engines with manually adjustable carburetors and thus should not be used in these engines.

Engines with M-Tronic deliver full engine performance using gasoline with an alcohol component of up to 25% (E25).

Engine oil

Use only high-quality two-stroke engine oil – ideally **STIHL HP, HP Super or HP Ultra two-stroke engine oil, as they are specially engineered for STIHL engines. HP Ultra ensures maximum performance and engine life.**

The engine oils are not available in all markets.

Only **STIHL two-cycle engine oil 1:50** may be used to produce the fuel mixture for machines with a catalytic converter.

Mixing ratio

for STIHL two-cycle engine oil 1:50;
1:50 = 1 part oil + 50 parts gasoline

Examples

Quantity of gasoline	STIHL two-cycle engine oil 1:50	
Liters	Liters	(ml)
1	0.02	(20)
5	0.10	(100)
10	0.20	(200)
15	0.30	(300)
20	0.40	(400)
25	0.50	(500)

- Pour oil into an approved safety fuel canister first, then add gasoline and mix thoroughly

Storing fuel mixture

Store in approved safety fuel canisters only in a dry, cool and secure place protected against light and sunlight.

Fuel mixture ages – mix only as much as needed for a few weeks. Do not store fuel mixture for longer than three months. The fuel mixture can become unusable faster if exposed to light, sunlight or low or high temperatures.

- Shake the canister containing the fuel mixture thoroughly before refueling

WARNING

Pressure can build up inside the canister – open carefully.

- The fuel tank and the canister in which fuel mixture is stored should be cleaned thoroughly from time to time

Residual fuel and the liquid used for cleaning must be disposed of in accordance with regulations and without harming the environment!

Fueling

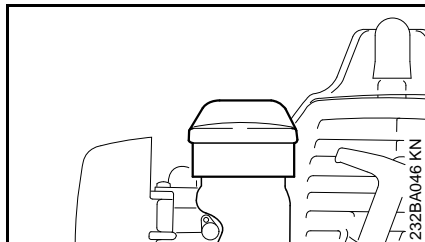

- Before fueling, clean the filler cap and the area around it to ensure that no dirt falls into the tank.
- Position the machine so that the filler cap is facing up.
- Open the filler cap.

Take care not to spill fuel while fueling and do not overfill the tank. STIHL recommends you use the STIHL filler nozzle (special accessory).

WARNING

After fueling, tighten down the filler cap as securely as possible by hand.

Fitting the Harness

The type and style of the harness depend on the market.

The use of the shoulder strap is described in the chapter on "Approved Combinations of Cutting Attachment, Deflector, Handle and Harness".

Shoulder strap

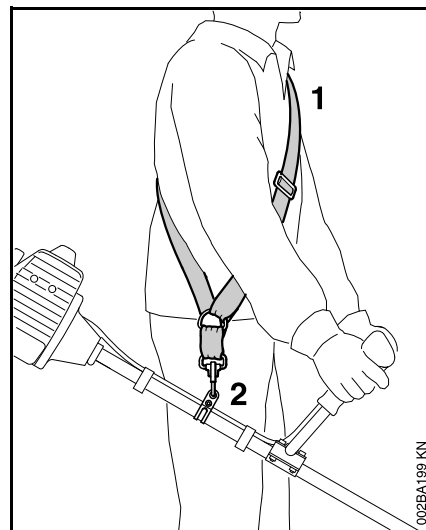

- Put on the shoulder strap (1).
- Adjust the length of the strap so that the spring hook (2) is about a hand's width below your right hip.
- Balance the trimmer/brushcutter.

Full harness

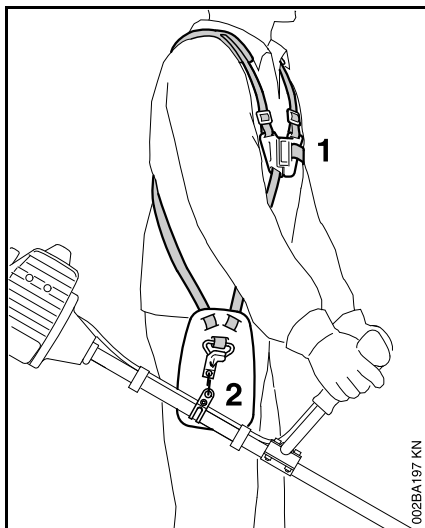

- Put on the full harness (1).
- Adjust the length of the strap so that the spring hook (2) is about a hand's width below your right hip.
- Balance the trimmer/brushcutter.

Balancing the Trimmer/Brushcutter

The type and style of the harness and carabiner (spring hook) depend on the market.

The carrying ring is integrated in the control handle on loop-handled units—see "Main Parts". Loop-handled units do not need to be balanced.

Attaching the unit to the harness

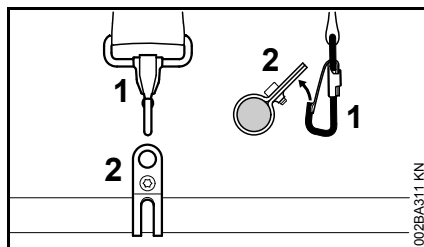

- Attach the carabiner (1) to the carrying ring (2) on the drive tube.

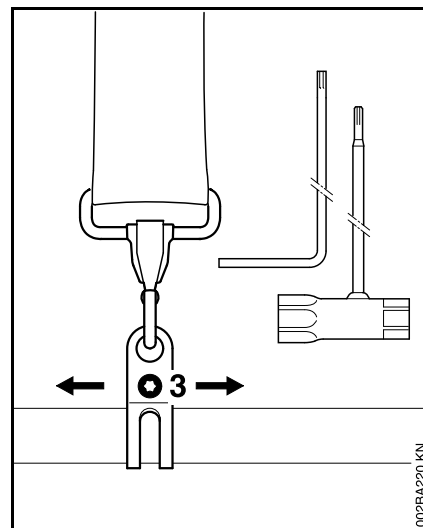

- Loosen the screw (3).

Floating position

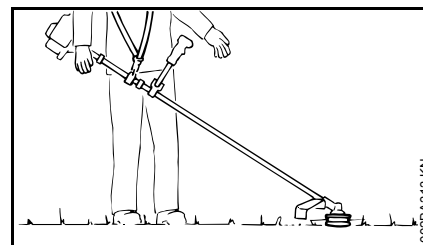

- Mowing heads and grass cutting blades should just touch the ground.

Proceed as follows to adjust the floating position:

- Move the carrying ring up or down the drive tube – tighten the screw moderately – let the unit go and wait until it is balanced – then check the floating position.

When the correct floating position has been reached:

- Tighten down the screw on the carrying ring firmly.

Detaching the unit from the harness

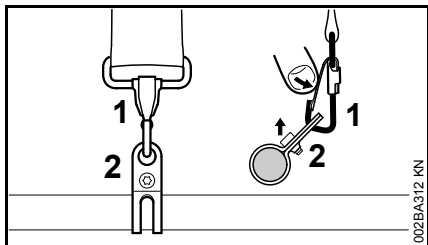

- Press down the bar on the carabiner (1) and pull the carrying ring (2) out of the carabiner.

Starting / Stopping the Engine

Version with Bike Handle

Controls

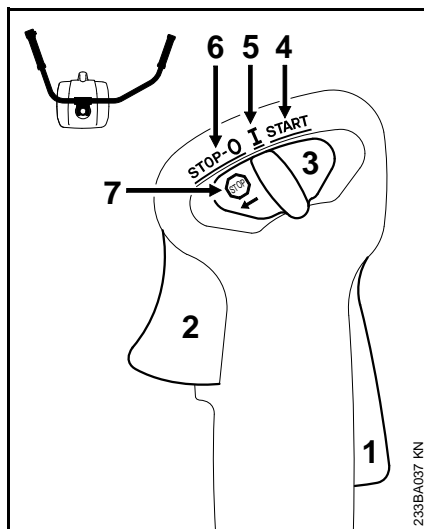

- 1 Throttle trigger lockout
- 2 Throttle trigger
- 3 Slide control

Positions of slide control

- 4 **START** – the ignition is switched on – the engine can start
- 5 **I** – normal run position – the engine is running or can start
- 6 **STOP-0** – engine off – the ignition is switched off

Symbol on slide control

- 7 – stop symbol and arrow. To stop the engine, push the slide control in the direction of the arrow on the stop symbol () to **STOP-0**.

Starting

- Press down the trigger lockout lever and squeeze the throttle trigger.
- and hold them in that position.
- Move the slide control to **START** and hold it there.
- Now release the throttle trigger, slide control and trigger lockout in that order. This is the **starting throttle position**.
- Go to "All versions".

Version with loop handle

Controls

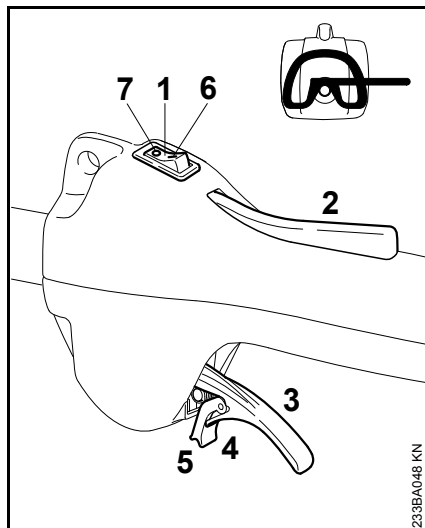

- 1 Stop switch
- 2 Throttle trigger lockout
- 3 Throttle trigger
- 4 Tongue of throttle trigger
- 5 Catch

Positions of stop switch

- 6 I – normal run position – the engine can start or is running
- 7 0 – Stop – engine off – the ignition is switched off

Starting

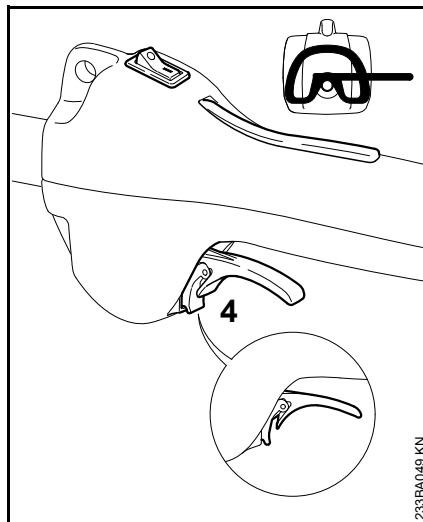

- Move the stop switch to I.
- Press down the throttle trigger lockout and hold it there.
- Squeeze the throttle trigger until the catch on the tongue (4) can be engaged on the housing.
- Now release the throttle trigger, tongue and trigger lockout in that order. This is the **starting throttle position**.
- Go to "All versions".

All versions

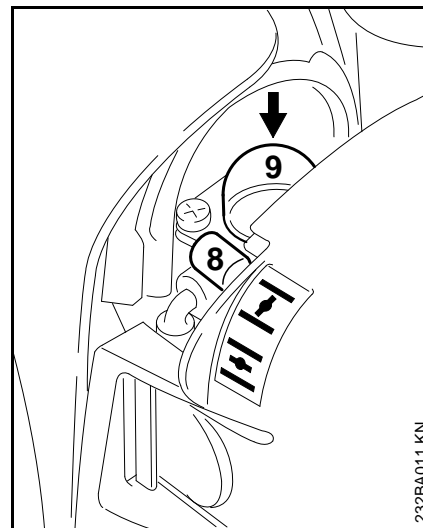

- Set the choke lever (8) to
 - I** if the engine is cold
 - II** for warm start – also use this position if the engine has been running but is still cold.
- Press the fuel pump bulb (9) at least five times – even if the bulb is already filled with fuel.

Starting

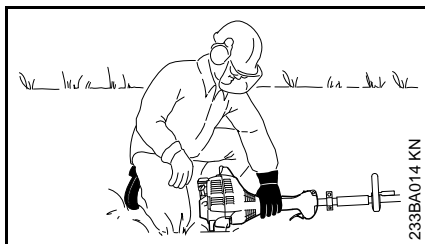
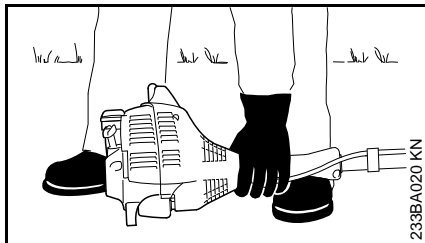

- Place the unit on the ground: It must rest securely on the engine support and the deflector. Check that the cutting attachment is not touching the ground or any other obstacles.
- Make sure you have a safe and secure footing.
- Hold the unit with your left hand and press it down **firmly** – your thumb should be under the fan housing.



NOTICE

Do not stand or kneel on the drive tube.

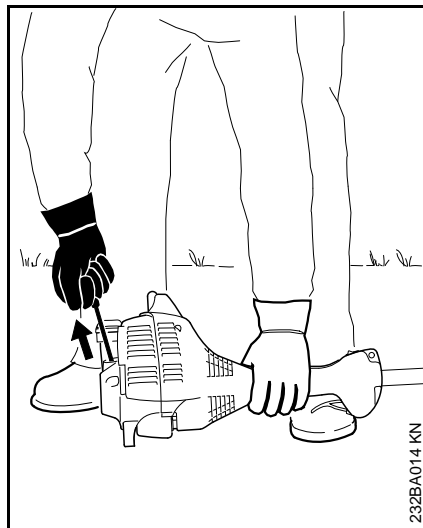

- Hold the starter grip with your right hand.

Version without ErgoStart

- Pull the starter grip slowly until you feel it engage and then give it a brisk strong pull.



NOTICE

Do not pull out the starter rope all the way – **it might otherwise break.**

Version with ErgoStart

- Pull the starter grip slowly until you feel it engage and then pull it out slowly and steadily.



NOTICE

Do not pull out the starter rope all the way – **it might otherwise break.**

Both versions

- Do not let the starter grip snap back. Guide it slowly back into the housing so that the starter rope can rewind properly.
- Continue cranking.

When the engine begins to fire:

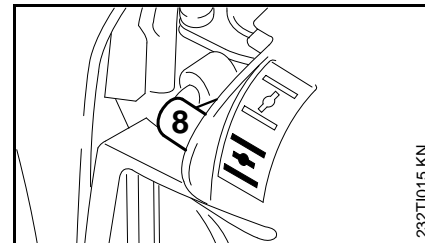

- After no more than **five** pulls, move the choke lever (8) to .
- Continue cranking.

As soon as the engine runs

Version with **bike handle**

- Blip the throttle trigger – the engine settles down to idle speed.

Version with **loop handle**

- Squeeze the throttle trigger to disengage the tongue – the engine will settle down to idle speed.

Your machine is now ready for operation.



WARNING

Make sure the carburetor is correctly adjusted. The cutting attachment must not rotate when the engine is idling.

Stopping the Engine

- Move the slide control in direction of the arrow (👉) to **STOP-0** or the stop switch to **STOP / 0**.

If the engine does not start

Choke lever

If you did not move the choke lever to  quickly enough after the engine began to fire, the combustion chamber is flooded.

- Set the choke lever to  .
- Set the slide control, trigger lockout lever and throttle trigger to the **starting throttle position**.
- Start the engine by pulling the starter rope briskly – 10 to 20 pulls may be necessary.

If the engine still does not start

- Move the slide control or stop switch to **STOP / 0**.
- Remove the spark plug – see "Spark Plug".
- Dry the spark plug.
- Crank the engine several times with the starter to clear the combustion chamber.
- Refit the spark plug – see "Spark Plug".
- Move the slide control or stop switch to **I / I**.
- Set the choke lever to  – even if the engine is cold.
- Now start the engine.

Fuel tank run until completely dry

- After refueling, press the fuel pump bulb at least five times – even if the bulb is filled with fuel.
- Set the choke lever to suit the engine temperature.
- Start the engine.

Operating Instructions

During break-in period

A factory-new machine should not be run at high revs (full throttle off load) for the first three tank fillings. This avoids unnecessary high loads during the break-in period. As all moving parts have to bed in during the break-in period, the frictional resistances in the engine are greater during this period. The engine develops its maximum power after about 5 to 15 tank fillings.

During Operation

After a long period of full throttle operation, allow the engine to run for a short while at idle speed so that engine heat can be dissipated by the flow of cooling air. This protects engine-mounted components (ignition, carburetor) from thermal overload.

After Finishing Work

Storing for a short period: Wait for the engine to cool down. Empty the fuel tank and keep the machine in a dry place, well away from sources of ignition, until you need it again. For longer out-of-service periods – see "Storing the Machine".

Cleaning the Air Filter

If there is a noticeable loss of engine power

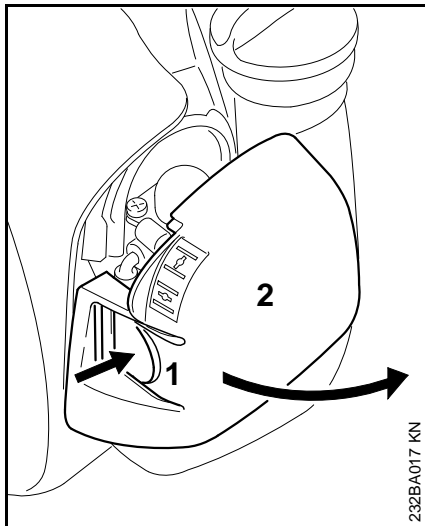

- Set the choke lever to \overline{I} .
- Press in the tab (1) and swing the filter cover (2) down.
- Clean away loose dirt from around the filter.

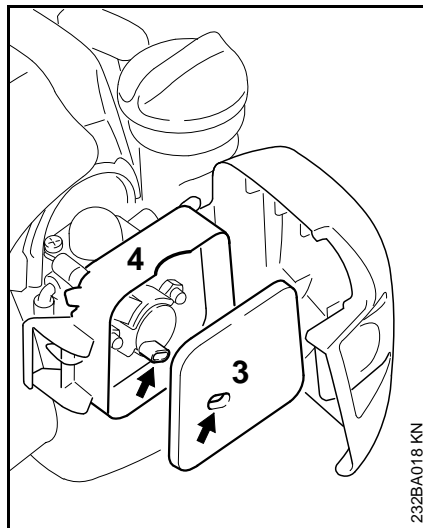

- Remove the felt element (3) from the filter housing (4) and replace it – knock out or blow out as a temporary measure – do not wash.
- Replace damaged parts.
- Fit the felt element (3) in the filter housing (4).
- Close the filter cover so that it snaps into position.

Adjusting the Carburetor

General Information

The carburetor comes from the factory with a standard setting.

This setting provides an optimum fuel-air mixture under most operating conditions.

Preparations

- Shut off the engine.
- Mounting the Cutting Attachment
- Check the air filter and clean or replace if necessary.
- Check the spark arresting screen (not in all models, country-specific) in the muffler and clean or replace if necessary.

FS 55 – Different Standard Settings

Different carburetors are installed at the factory. A different standard setting is necessary for each of these carburetors.

Standard setting A

- High speed screw (H) = 3/4
- Low speed screw (L) = 1 1/2

Standard setting B

- High speed screw (H) = 3/4
- Low speed screw (L) = 3/4

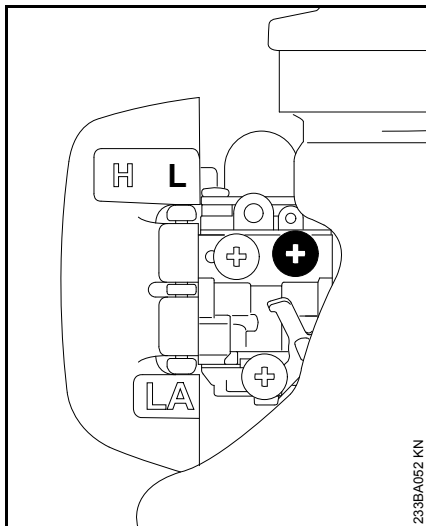

233BA052 KN

- Determine the standard setting as follows: Turn the low speed screw (L) carefully clockwise as far as stop, then turn it counterclockwise.

Is range of adjustment more than 1 turn?

- Continue with "**Standard setting A**"

Is range of adjustment less than 1 turn?

- Continue with "**Standard setting B**"

Standard setting A

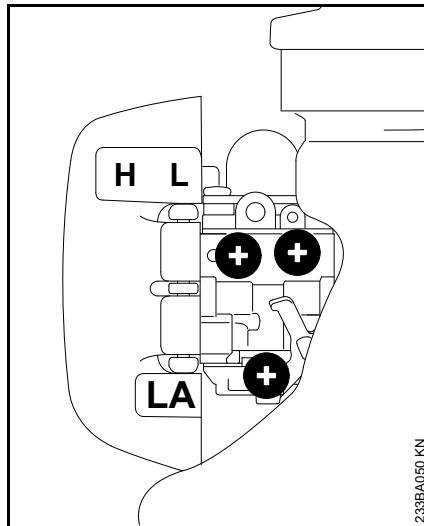

233BA050 KN

- Turn high speed screw (H) counterclockwise as far as stop (no more than 3/4 turn).
- Turn the low speed screw (L) carefully clockwise until it is against its seat, then turn it back 1 1/2 turns.

Standard setting B

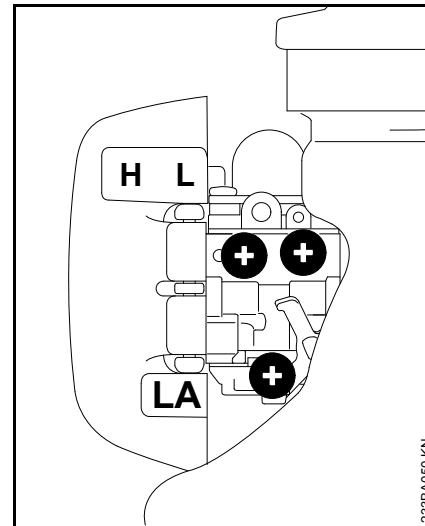

233BA050 KN

- Turn high speed screw (H) counterclockwise as far as stop (no more than 3/4 turn).
- Turn the low speed screw (L) carefully clockwise as far as stop, then turn it back 3/4 turn.

Standard Setting – FS 55 2-MIX

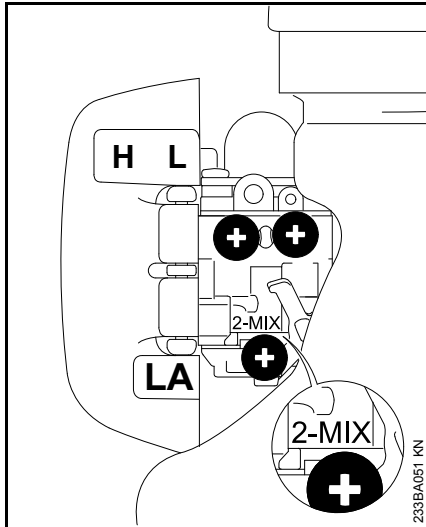

- Turn high speed screw (H) counterclockwise as far as stop (no more than 3/4 turn).
- Turn the low speed screw (L) carefully clockwise until it is against its seat, then it back off a 3/4 turn.

Adjusting Idle Speed – All Models

- Carry out the standard setting.
- Start and warm up the engine.

Engine stops while idling

- Turn the idle speed screw (LA) slowly clockwise until the engine runs smoothly – the cutting attachment must not rotate.

Cutting attachment rotates when engine is idling

- Turn the idle speed screw (LA) counterclockwise until the cutting attachment stops moving and then turn the screw another 1/2 to 1 full turn in the same direction.

! WARNING

If the cutting attachment continues to rotate when the engine is idling, have your machine checked and repaired by your servicing dealer.

Erratic idling behavior, poor acceleration (despite correction to setting of LA screw).

Idle setting is too lean

FS 55

- Rotate the low speed screw (L) slowly about 1/4 turn counterclockwise until the engine runs and accelerates smoothly.

FS 55 2-MIX

- Turn the low speed screw (L) counterclockwise, no further than stop, until the engine runs and accelerates smoothly.

Erratic idling behavior

Idle setting is too rich

FS 55

- Rotate the low speed screw (L) slowly about 1/4 turn clockwise until the engine runs smoothly and still accelerates satisfactorily.

FS 55 2-MIX

- Turn the low speed screw (L) slowly clockwise, no further than stop, until the engine runs and accelerates smoothly.

It is usually necessary to change the setting of the idle speed screw (LA) after every correction to the low speed screw (L).

Fine Tuning for Operation at High Altitude

A slight correction of the setting may be necessary if engine does not run satisfactorily:

- Carry out the standard setting.
- Warm up the engine.
- Turn high speed screw (H) slightly clockwise (leaner) – no further than stop.

⚙ NOTICE

After returning from high altitude, reset the carburetor to the standard setting.

If the setting is too lean there is a risk of engine damage due to insufficient lubrication and overheating.

Spark Plug

- If the engine is down on power, difficult to start or runs poorly at idle speed, first check the spark plug.
- Fit a new spark plug after about 100 operating hours – or sooner if the electrodes are badly eroded. Install only suppressed spark plugs of the type approved by STIHL – see "Specifications".

Removing the Spark Plug

- Move the stop switch to 0.

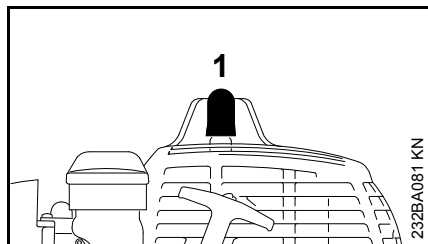

- Pull off the spark plug boot (1).
- Unscrew the spark plug.

Checking the spark plug

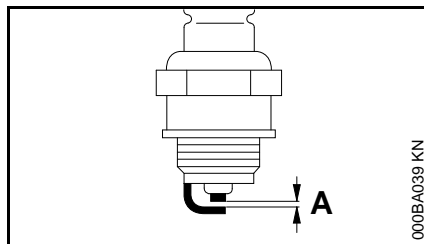

- Clean dirty spark plug.
- Check electrode gap (A) and readjust if necessary – see "Specifications".
- Rectify the problems which have caused fouling of the spark plug.

Possible causes are:

- Too much oil in fuel mix.
- Dirty air filter.
- Unfavorable running conditions.

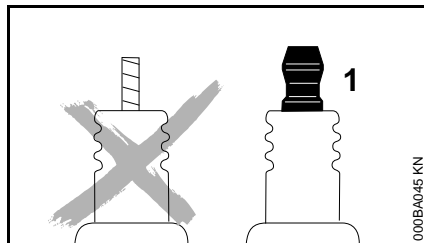

WARNING

If the spark plug comes with a detachable adapter nut (1), screw the adapter onto the thread and tighten it down **firmly** to reduce the **risk of arcing and fire**.

Installing the spark plug

- Screw home the spark plug, fit the boot and press it down firmly.

Engine Running Behavior

If engine running behavior is unsatisfactory even though the air filter is clean and the carburetor is properly adjusted, the cause may be the muffler.

Have the muffler checked for contamination (carbonization) by your servicing dealer.

STIHL recommends that you have servicing and repair work carried out exclusively by an authorized STIHL servicing dealer.

Rewind Starter

To help prolong the wear life of the starter rope, observe the following points:

- Pull the starter rope only in the direction specified.
- Do not pull the rope over the edge of the guide bushing.
- Do not pull out the rope more than specified.
- Do not allow the starter grip to snap back, guide it back into the housing slowly – see chapter on "Starting / Stopping the Engine."

Have a damaged starter rope replaced by your dealer before it breaks completely. STIHL recommends that you have servicing and repair work carried out exclusively by an authorized STIHL servicing dealer.

Lubricating the Gearbox

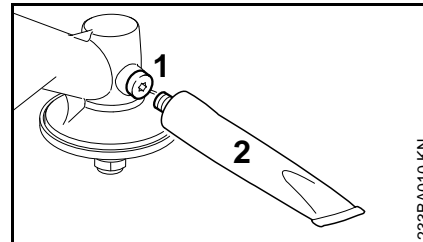

- Check the grease level regularly – about every 25 hours of operation.
- Unscrew the filler plug (1). If no grease can be seen on the inside of the filler plug, screw the tube (2) of STIHL gear lubricant for brushcutters (special accessory) into the filler hole.
- Squeeze up to 5 g grease into the gearbox.



Do not completely fill the gearbox with grease.

- Remove the tube of grease (2).
- Refit the filler plug (1) and tighten it down firmly.

Storing the Machine

For periods of 3 months or longer

- Drain and clean the fuel tank in a well ventilated area.
- Dispose of fuel properly in accordance with local environmental requirements.
- Run the engine until the carburetor is dry – this helps prevent the carburetor diaphragms sticking together.
- Remove, clean and inspect the cutting attachment.
- Thoroughly clean the machine – pay special attention to the cylinder fins and air filter.
- Store the machine in a dry and secure location – out of the reach of children and other unauthorized persons.

Sharpening Metal Cutting Blades

- Use a sharpening file (see "Special Accessories") to sharpen dull cutting attachments. In case of more serious wear or nicks: Resharpener with a grinder or have the work done by a dealer – STIHL recommends a STIHL servicing dealer.
- Resharpener frequently, take away as little material as possible: two or three strokes of the file are usually enough.

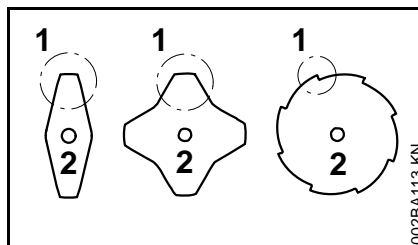

- Resharpener the cutters (1) uniformly – do not alter the contour or the parent blade (2) in any way.

See cutting attachment packaging for additional sharpening instructions.

Balancing

- After resharpening about 5 times, check the cutting attachment for out-of-balance on a STIHL balancer – see "Special Accessories" – or have it checked by a dealer and re-balanced as necessary – STIHL recommends a STIHL servicing dealer.

Inspections and Maintenance by Dealer

Maintenance Work

STIHL recommends that you have servicing and repair work carried out exclusively by an authorized STIHL servicing dealer.

Fuel Pickup Body in Tank

- Have the pickup body in the fuel tank replaced every year.

Spark Arrestor in Muffler

- If the engine is low on power, have your dealer check the spark arrestor (country-specific option) in the muffler.

Maintenance and Care

The following intervals apply to normal operating conditions only. If your daily working time is longer or operating conditions are difficult (very dusty work area, etc.), shorten the specified intervals accordingly.		before starting work	after finishing work or daily	after each refueling stop	weekly	monthly	every 12 months	if problem	if damaged	if required
Complete machine	Visual inspection (condition, leaks)	X		X						
	Clean		X							
Control handle	Check operation	X		X						
Air filter	Clean							X		X
	Replace								X	
Pickup body in fuel tank	Check							X		
	Have replaced by dealer ¹⁾						X		X	X
Fuel tank	Clean							X		X
Carburetor	Check idle adjustment – the cutting attachment must not turn	X		X						
	Readjust idle speed									X
Spark plug	Readjust electrode gap							X		
	Replace after every 100 operating hours									
Cooling inlets	Visual inspection		X							
	Clean									X
Spark arrestor ²⁾ in muffler	Have checked by dealer ¹⁾		X					X		
	Have cleaned or replaced by servicing dealer ¹⁾								X	X
All accessible screws and nuts (not adjusting screws)	Retighten									X

The following intervals apply to normal operating conditions only. If your daily working time is longer or operating conditions are difficult (very dusty work area, etc.), shorten the specified intervals accordingly.		before starting work	after finishing work or daily	after each refueling stop	weekly	monthly	every 12 months	if problem	if damaged	if required
Cutting attachment	Visual inspection	X		X						
	Replace								X	
	Check tightness	X		X						
Metal cutting attachment	Sharpen	X								X
Safety labels	Replace								X	

1) STIHL recommends a STIHL servicing dealer.

2) not in all versions, market-specific

Minimize Wear and Avoid Damage

Observing the instructions in this manual helps reduce the risk of unnecessary wear and damage to the power tool.

The power tool must be operated, maintained and stored with the due care and attention described in this owner's manual.

The user is responsible for all damage caused by non-observance of the safety precautions, operating and maintenance instructions in this manual. This includes in particular:

- Alterations or modifications to the product not approved by STIHL.
- Using tools or accessories which are neither approved or suitable for the product or are of a poor quality.
- Using the product for purposes for which it was not designed.
- Using the product for sports or competitive events.
- Consequential damage caused by continuing to use the product with defective components.

Maintenance Work

All the operations described in the "Maintenance Chart" must be performed on a regular basis. If these maintenance operations cannot be performed by the owner, they should be performed by a servicing dealer.

STIHL recommends that you have servicing and repair work carried out exclusively by an authorized STIHL

servicing dealer. STIHL dealers are regularly given the opportunity to attend training courses and are supplied with the necessary technical information.

If these maintenance operations are not carried out as specified, the user assumes responsibility for any damage that may occur. Among other parts, this includes:

- Damage to the engine due to neglect or deficient maintenance (e.g. air and fuel filters), incorrect carburetor adjustment or inadequate cleaning of cooling air inlets (intake ports, cylinder fins).
- Corrosion and other consequential damage resulting from improper storage.
- Damage to the machine resulting from the use of poor quality replacement parts.

Parts Subject to Wear and Tear

Some parts of the power tool are subject to normal wear and tear even during regular operation in accordance with instructions and, depending on the type and duration of use, have to be replaced in good time. Among other parts, this includes:

- Cutting attachments (all types)
- Mounting hardware for cutting attachments (rider plate, nut, etc.)
- Deflectors for cutting attachments
- Clutch
- Filters (air, fuel)

- Rewind starter
- Spark plug

Main Parts

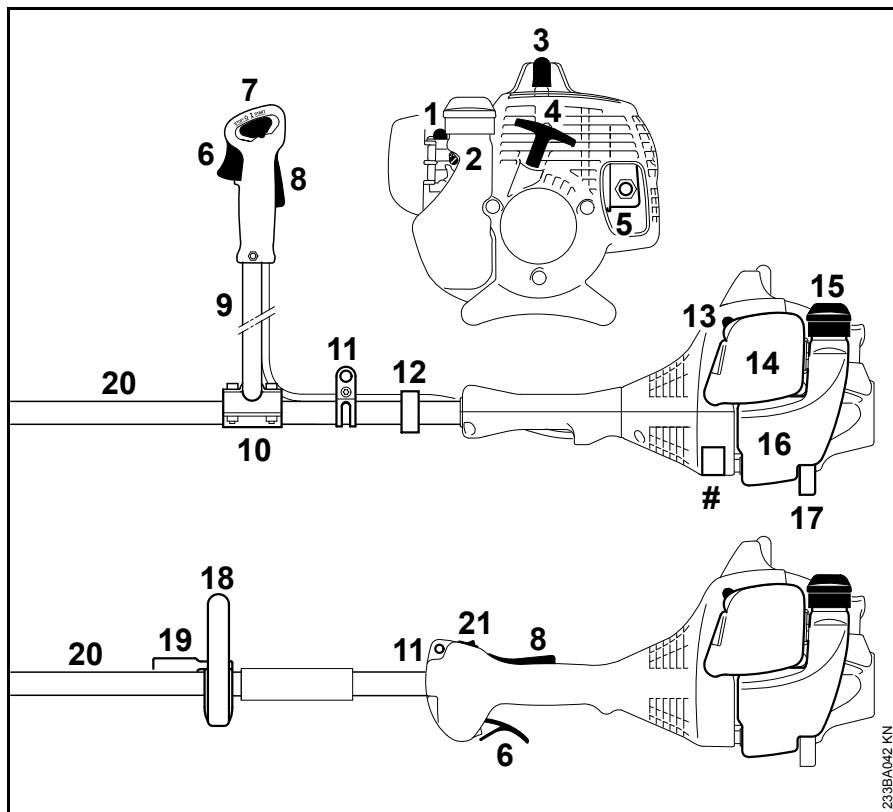

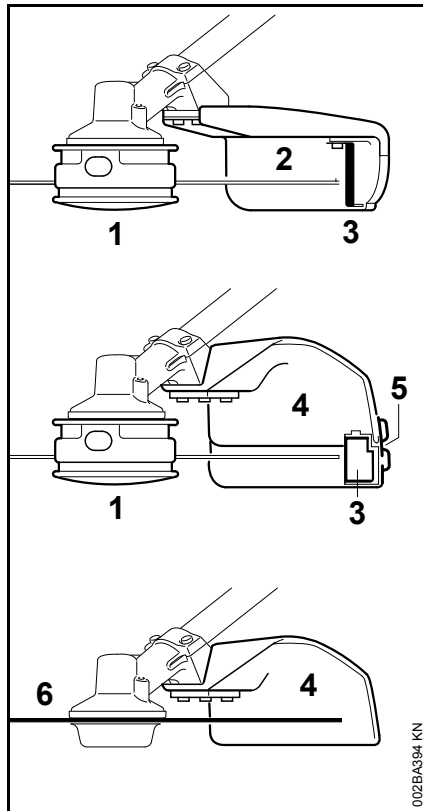

- 1 Mowing head
- 2 Deflector for mowing heads only
- 3 Blade
- 4 Deflector for all mowing attachments
- 5 Skirt
- 6 Metal mowing attachment

Specifications

Engine

Single cylinder two-stroke engine

FS 55

Displacement:	27.2 cm ³
Bore:	34 mm
Stroke:	30 mm
Engine power to ISO 8893:	0.75 kW (1 HP) at 7,000 rpm
Idle speed:	2,800 rpm
Cut-off speed (rated):	9,500 rpm
Max. output shaft speed (cutting attachment):	7,700 rpm

FS 55 2-MIX

Displacement:	27.2 cm ³
Bore:	34 mm
Stroke:	30 mm
Engine power to ISO 8893:	0.75 kW (1 HP) at 8,500 rpm
Idle speed:	2,800 rpm
Cut-off speed (rated):	10,000 rpm
Max. output shaft speed (cutting attachment):	8,100 rpm

Ignition System

Electronic magneto ignition

Spark plug (resistor type):	Bosch WSR 6 F, NGK BPMR 7 A
Electrode gap:	0.5 mm

Fuel System

All position diaphragm carburetor with integral fuel pump

Fuel tank capacity: 0.33 l

Weight

dry, without cutting attachment and deflector

FS 55:	5.0 kg
FS 55 2-MIX:	5.1 kg
FS 55 C: with ErgoStart:	5.2 kg
FS 55 R:	4.8 kg
FS 55 R 2-MIX:	4.9 kg
FS 55 RC: with ErgoStart:	5.0 kg

Noise and Vibration Data

Noise and vibration data measurements include idling and rated maximum speed with the same duration of exposure.

For further details on compliance with Vibration Directive 2002/44/EC see www.stihl.com/vib/

Sound pressure level L_{peq} to ISO 7917

with mowing head

FS 55 with bike handle:	95 dB(A)
FS 55 R:	95 dB(A)

with metal mowing attachment

FS 55 with bike handle:	94 dB(A)
FS 55 R with barrier bar:	94 dB(A)

Sound power level L_{weq} to ISO 10884

with mowing head

FS 55 with bike handle: 106 dB(A)

FS 55 R: 106 dB(A)

with metal mowing attachment

FS 55 with bike handle: 103 dB(A)

FS 55 R with barrier bar: 104 dB(A)

Vibration measurement $a_{hv,eq}$ to ISO 22867

	Handle, left	Handle, right
with mowing head		

FS 55 with bike handle:	5.5 m/s ²	4.7 m/s ²
-------------------------	----------------------	----------------------

FS 55 R:	7.2 m/s ²	7.7 m/s ²
----------	----------------------	----------------------

	Handle, left	Handle, right
with metal mowing attachment		

FS 55 with bike handle:	7.3 m/s ²	5.5 m/s ²
-------------------------	----------------------	----------------------

FS 55 R with barrier bar:	8.3 m/s ²	9.0 m/s ²
---------------------------	----------------------	----------------------

The K-factor in accordance with Directive 2006/42/EC is 2.5 dB(A) for the sound pressure level and sound power level; the K-factor in accordance with Directive 2006/42/EC is 2.0 m/s² for the vibration measurement.

REACH

REACH is an EC regulation and stands for the Registration, Evaluation, Authorisation and Restriction of Chemical substances.

For information on compliance with the REACH regulation (EC) No. 1907/2006 see www.stihl.com/reach.

Special Accessories**Cutting attachments****Mowing heads**

1 Mowing head STIHL SuperCut 20-2

2 Mowing head STIHL AutoCut C 25-2

3 Mowing head STIHL AutoCut 25-2

4 Mowing head STIHL TrimCut 31-2

5 Mowing head STIHL FixCut 25-2

6 Mowing head STIHL PolyCut 20-3

Metal cutting attachments

7 Grass cutting blade 230-2

8 Grass cutting blade 230-4

9 Grass cutting blade 230-8

**WARNING**

The cutting attachments may only be used in accordance with the instructions in the chapter "Selecting the cutting attachment".

Special accessories for cutting attachments

- Mowing line for mowing heads, for Items 1 – 6
- Spool with mowing line, for Items 1 – 4
- Plastic blades, set of 12, for Item 6
- Transport guard for Items 7 – 9

Sharpening aids for metal cutting attachments

- Flat sharpening files for Items 7 – 9
- STIHL balancer for Items 7 – 9

Fasteners for metal cutting attachments

- Thrust plate
- Thrust washer
- Rider plate
- Nut

Other special accessories

- Safety glasses
- Barrier bar
- Shoulder strap
- Full harness
- Combination wrench
- Locking pin
- Hex key wrench
- Carburetor screwdriver
- STIHL ElastoStart (starter rope with grip) for machines without ErgoStart

Ask your STIHL dealer for current information on this and other special accessories.

Maintenance and Repairs

Users of this machine may only carry out the maintenance and service work described in this user manual. All other repairs must be carried out by a servicing dealer.

STIHL recommends that you have servicing and repair work carried out exclusively by an authorized STIHL servicing dealer. STIHL dealers are regularly given the opportunity to attend training courses and are supplied with the necessary technical information.

When repairing the machine, only use replacement parts which have been approved by STIHL for this power tool or are technically identical. Only use high-quality replacement parts in order to avoid the risk of accidents and damage to the machine.

STIHL recommends the use of original STIHL replacement parts.

Original STIHL parts can be identified by the STIHL part number, the **STIHL** logo and the STIHL parts symbol  (the symbol may appear alone on small parts).

Disposal

Observe all country-specific waste disposal rules and regulations.

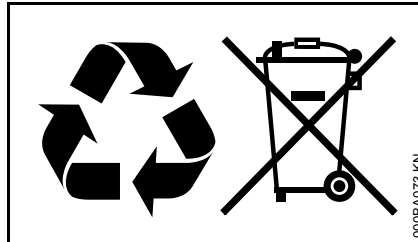

STIHL products must not be thrown in the garbage can. Take the product, accessories and packaging to an approved disposal site for environment-friendly recycling.

Contact your STIHL servicing dealer for the latest information on waste disposal.

EC Declaration of Conformity

ANDREAS STIHL AG & Co. KG
Badstr. 115
D-71336 Waiblingen

confirms that the product described below

Category:	Trimmer
Make:	STIHL
Model:	FS 55
	FS 55 C
	FS 55 C-E
	FS 55 R
	FS 55 RC
	FS 55 RC-E

Serial identification:	4140
Displacement:	27.2 cm ³

conforms to the specifications of Directives 2006/42/EC, 2004/108/EC and 2000/14/EC and has been developed and manufactured in compliance with the following standards:

EN ISO 11806, EN 55012,
EN 61000-6-1

The measured and guaranteed sound power levels were determined according to Directive 2000/14/EC, Annex V, using the ISO 10884 standard.

Measured sound power level

109 dB(A)

Guaranteed sound power level

111 dB(A)

Technical documents deposited at:

ANDREAS STIHL AG & Co. KG
Produktzulassung (Product Licensing)

The year of manufacture and serial
number are applied to the product.

Done at Waiblingen, 01.08.2012

ANDREAS STIHL AG & Co. KG



Thomas Elsner

Director Group Product Management



Quality Certification



All STIHL products comply with the
highest quality standards.

An independent organization has
certified that all products manufactured
by STIHL meet the strict requirements of
the ISO 9001 standard for quality
management systems in terms of
product development, materials
purchasing, production, assembly,
documentation and customer service.

0458-233-0121-E

englisch



www.stihl.com

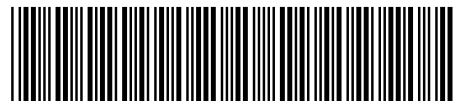

0458-233-0121-E