

MS 194 T

STIHL



2 - 27 Instruction Manual



Contents

1	Introduction.....	2
2	Guide to Using this Manual.....	2
3	Overview.....	2
4	Safety Precautions.....	4
5	Preparing the Saw for Operation.....	10
6	Assembling the Saw.....	10
7	Engaging and Disengaging the Chain Brake	12
8	Mixing Fuel and Refueling the Chainsaw..	13
9	Starting and Stopping the Engine.....	14
10	Checking the Saw.....	15
11	Operating the Saw.....	17
12	After Finishing Work.....	19
13	Transporting.....	19
14	Storing.....	19
15	Cleaning.....	20
16	Maintenance.....	22
17	Repairing.....	22
18	Troubleshooting.....	22
19	Specifications.....	24
20	Bar and Chain Combinations.....	25
21	Spare Parts and Accessories.....	26
22	Disposal.....	26
23	EC Declaration of Conformity.....	26
24	UKCA Declaration of Conformity.....	27

1 Introduction

Dear Customer,

Thank you for choosing STIHL. We develop and manufacture our quality products to meet our customers' requirements. The products are designed for reliability even under extreme conditions.

STIHL also stands for premium service quality. Our dealers guarantee competent advice and instruction as well as comprehensive service support.

STIHL expressly commit themselves to a sustainable and responsible handling of natural resources. This user manual is intended to help you use your STIHL product safely and in an environmentally friendly manner over a long service life.

We thank you for your confidence in us and hope you will enjoy working with your STIHL product.



Dr. Nikolas Stihl

IMPORTANT! READ BEFORE USING AND KEEP IN A SAFE PLACE FOR REFERENCE.

2 Guide to Using this Manual

2.1 Symbols used with warnings in the text

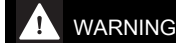

- This symbol indicates dangers that can cause serious injuries or death.
 - ▶ The measures indicated can avoid serious injuries or death.

NOTICE

- This symbol indicates dangers that can cause damage to property.
 - ▶ The measures indicated can avoid damage to property.

2.2 Symbols in Text

-  This symbol refers to a chapter in this instruction manual.

3 Overview

3.1 Chainsaw

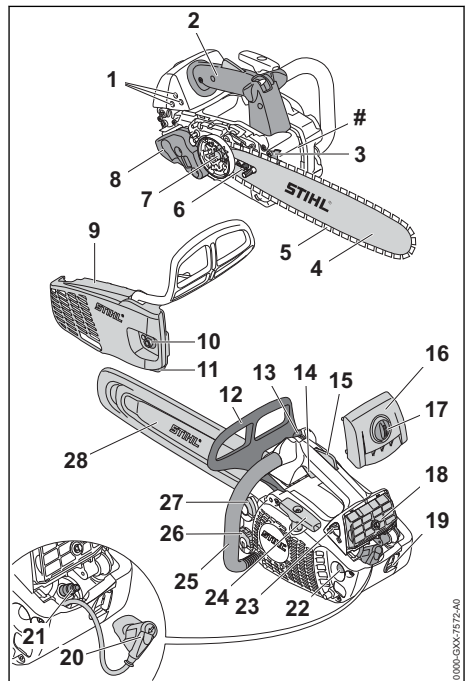

- 1 Carburetor Adjusting Screws**
For tuning the carburetor.
- 2 Rear Handle**
For operating, holding, controlling and carrying the chainsaw.
- 3 Spiked Bumper**
Toothed stop for holding saw steady against wood while cutting.
- 4 Guide Bar**
Supports and guides the saw chain.
- 5 Saw Chain**
Cuts the wood.
- 6 Tensioning Screw**
Adjusts chain tension.
- 7 Chain Sprocket**
Toothed wheel that drives the chain.
- 8 Muffler**
Reduces chainsaw noise emissions.
- 9 Chain Sprocket Cover**
Covers the chain sprocket and secures the guide bar to the chainsaw.
- 10 Nut**
Secures chain sprocket cover to chainsaw.
- 11 Chain Catcher**
Reduces risk of operator contact with the chain if it comes off the bar or breaks.
- 12 Front Hand Guard**
Helps protect operator's left hand from contact with the saw chain, serves to engage the chain brake and activates the chain brake by inertia in certain kickback situations.
- 13 Master Control Lever**
For starting, running and stopping the engine.
- 14 Throttle Lever**
Controls engine speed.
- 15 Throttle Trigger Lockout**
Unlocks the throttle trigger.
- 16 Shroud**
Covers the engine.
- 17 Shroud Lock**
Secures shroud to chainsaw
- 18 Air Filter**
Filters the air entering the engine.
- 19 Ring**
For hanging up the saw while working in the tree.
- 20 Spark Plug Boot**
Connects ignition lead to spark plug

- 21 Spark Plug**
Ignites fuel-air mixture in the engine.
- 22 Manual fuel pump**
Eases engine starts.
- 23 Choke Lever**
Enriches mixture for engine starts.
- 24 Starter Grip**
Serves to crank the engine.
- 25 Handlebar**
For holding and controlling the chainsaw.
- 26 Oil Tank Cap**
Closes the oil tank.
- 27 Fuel Tank Cap**
Closes the fuel tank.
- 28 Chain Scabbard**
Helps protect user from contact with saw chain.

Serial Number

3.2 Symbols

Meanings of symbols that may be on the chainsaw:



This symbol marks the fuel tank.



This symbol marks the chain oil tank.



The chain brake is engaged or disengaged in this direction.



This symbol shows the direction of rotation of the chain.



Rotate in this direction to increase chain tension.



This symbol denotes the manual fuel pump.



Master Control lever is moved in this direction to stop the engine.



Master Control lever is moved to this position to stop the engine.



Engine is operated with the Master Control lever in this position.



Engine is started with the Master Control lever in this position.



Engine is made ready for start with the choke lever in this position.



Engine is started with the choke lever in this position.



L_{WA} Guaranteed sound power level according to directive 2000/14/EC in dB(A) in order to make sound emissions of products comparable.

4 Safety Precautions

4.1 Warning Symbols

Meanings of warning signs on the chainsaw:



Observe safety notices and take the necessary precautions.



Read, understand and save the instruction manual.



Wear safety glasses, hearing protection and a hard hat.



Wear long trousers with cut-retardant inserts and cut-retardant sleeves on both arms.



Hold the saw firmly with both hands.



Observe safety notices on kickback and take the necessary precautions.



Only persons who have been trained in the use of a tree service chainsaw may use this chainsaw.

4.2 Intended Use

The STIHL MS 194 T tree service chainsaw is designed for tree surgery work and cutting in the crown of the standing tree.

The chainsaw must not be used for work on the ground.

The ring serves to secure the chainsaw on a chainsaw stop featuring overload protection and to transport the saw into the tree at the strap or using a rope.

▲ WARNING

- Using the chainsaw for purposes for which it is not designed may result in serious or fatal injuries and damage to property.
 - ▶ Always use the chainsaw as described in this User Manual.

4.3 The Operator

▲ WARNING

- Persons who have not been trained in tree surgery and maintenance techniques with a

tree service chainsaw cannot recognize or assess the dangers of the chainsaw. The user or other persons may sustain serious or fatal injuries.



- ▶ Read, understand and save the instruction manual.



- ▶ Only persons who have been trained in the use of a tree service chainsaw may use this chainsaw.

- ▶ If the chainsaw is passed on to another person: Always give them the instruction manual.
- ▶ Make sure the user meets the following requirements:
 - The user must be rested.
 - The user must be in good physical condition and mental health to operate and work with the chainsaw.
 - The user is able to recognize and assess the risks involved in using the chainsaw.
 - The user must be of legal age or is being trained in a trade under supervision in accordance with national rules and regulations.
 - The user has received instruction from a STIHL servicing dealer or other experienced user before working with the chainsaw for the first time.
 - The user must not be under the influence of alcohol, medication or drugs.
- ▶ If you have any queries: Contact a STIHL servicing dealer for assistance.
- The chainsaw's ignition system produces an electromagnetic field. This field may interfere with some pacemakers. This can result in serious or fatal injuries.
 - ▶ If the user has a pacemaker: Make sure the pacemaker is not affected.

4.4 Clothing and equipment

▲ WARNING

- Long hair may be pulled into the chainsaw while working. This may result in serious injury to the user.
 - ▶ Tie up and confine long hair above your shoulders.
- Objects can be thrown at high speed during operation. This may result in injury to the user.



- ▶ Wear close-fitting safety glasses. Suitable safety glasses are tested in accordance with EN 166 or national regulations and available commer-

cially with the corresponding marking.

- ▶ STIHL recommends wearing a face mask.
- ▶ Wear a long-sleeved, close fitting top.
- Noise is generated during operation. Noise can damage your hearing.



- ▶ Wear ear protection.

- Falling objects can cause head injuries.



- ▶ If objects are likely to fall while working: wear a hard hat.

- Dust can be whipped up during operation: Whipped up dust can damage the respiratory passages and cause allergic reactions.
 - ▶ If dust is whipped up or forms a cloud: Wear a dust respirator mask.
- Unsuitable clothing can snag on wood or scrub and may become caught in the chain saw. Users not wearing suitable clothing are at risk of serious injury.
 - ▶ Wear close-fitting clothing.
 - ▶ Remove scarves and jewelry.
- The user may come into contact with the moving saw chain while working. This may result in serious injury to the user.



- ▶ Wear long trousers with cut-retardant inserts and cut-retardant sleeves on both arms.

- The user may cut himself or herself on wood while working. The user may come into contact with the saw chain during cleaning or servicing. This may result in injury to the user.
 - ▶ Wear work gloves made from resistant material.
- Wearing unsuitable footwear may cause the user to slip. If the user comes into contact with the moving saw chain, he or she may suffer cuts. This may result in injury to the user.
 - ▶ Wear chainsaw boots with cut protection.
- When working in a tree there is risk of the operator falling. This may result in serious or fatal injury to the user.
 - ▶ Use personal fall protection equipment.

4.5 Work Area and Surroundings

▲ WARNING

- Bystanders, children and animals are not aware of the dangers of the chainsaw or thrown objects. Innocent bystanders, children and animals may be seriously injured and damage to property may occur.

- ▶ Keep bystanders, children and animals away from the work area.
- ▶ Do not leave the chainsaw unattended.
- ▶ Make sure that children cannot play with the chainsaw.
- Hot exhaust gas is emitted through the muffler while the engine is running. Hot exhaust gas can ignite easily flammable materials and cause a fire.
 - ▶ Keep exhaust gas well away from easily flammable materials.

4.6 Safe Condition

4.6.1 Chainsaw

The chainsaw is in a safe condition if the following points are observed:

- The chainsaw is not damaged.
- There is no fuel leaking from the chainsaw.
- The fuel tank and oil tank caps are closed.
- The chainsaw is clean.
- The ring is not damaged.
- The chain catcher is fitted and undamaged.
- The chain brake is operating properly.
- The controls function properly and have not been modified.
- The chain lubrication is operating properly.
- Wear marks on the chain sprocket are not deeper than 0.5 mm.
- A combination of guide bar and saw chain recommended in this User Manual is mounted.
- The guide bar and saw chain are properly mounted.
- The saw chain is properly tensioned.
- Only original STIHL accessories designed for this chainsaw model are fitted.
- The accessories are correctly attached.

▲ WARNING

- If not in safe condition, components may no longer operate correctly, safety devices may be disabled and fuel leakage may occur. There is a risk of serious or fatal injury.
 - ▶ Work only with an undamaged chainsaw.
 - ▶ If fuel is leaking from the chainsaw: Do not use the chainsaw and contact a STIHL dealer for assistance.
 - ▶ Close the fuel tank and oil tank caps.
 - ▶ If the chainsaw is dirty: Clean the chainsaw.
 - ▶ Use chainsaw with an undamaged ring.
 - ▶ Work only with property fitted and undamaged chain catcher.
 - ▶ Never modify your chainsaw. Exception: Mounting a combination of guide bar and saw chain recommended in this User Manual.

- ▶ If the controls do not function properly: Do not use your chainsaw.
- ▶ Only fit original STIHL accessories designed for this chainsaw model.
- ▶ Mount the guide bar and saw chain as described in this User Manual.
- ▶ Attach accessories as described in this User Manual or in the User Manual for the accessories.
- ▶ Never insert objects in the chainsaw's openings.
- ▶ Replace worn or damaged labels.
- ▶ If you are unsure: Consult a STIHL authorized dealer.

4.6.2 Guide Bar

The guide bar is in a safe condition if the following points are observed:

- Guide bar is not damaged.
- Guide bar is not deformed.
- The minimum groove depth is maintained,  19.3.
- Bar rails are free from burrs.
- Bar groove is not pinched or splayed.

▲ WARNING

- If the guide bar is not in a safe condition, it can no longer support and guide the saw chain properly. The rotating saw chain can jump off the guide bar. This can result in serious or fatal injuries.
 - ▶ Work only with an undamaged guide bar.
 - ▶ If the groove depth is less than the minimum depth: Mount a new guide bar.
 - ▶ Deburr the guide bar every week.
 - ▶ If you have any queries: Contact your STIHL servicing dealer.

4.6.3 Saw Chain

The saw chain is in a safe condition if the following points are observed:

- Chain is not damaged.
- Chain is properly sharpened.
- The service marks on the cutters are still visible.

▲ WARNING

- If components do not comply with safety requirements, they will no longer function properly and safety devices may be rendered inoperative. This can result in serious or fatal injuries.
 - ▶ Work only with an undamaged saw chain.
 - ▶ Sharpen the chain properly.
 - ▶ If you have any queries: Contact your STIHL servicing dealer for assistance.

4.7 Fuel Mixture and Refueling

▲ WARNING

- This chainsaw requires a fuel mixture of gasoline and two-stroke engine oil. Mixed fuel and gasoline are extremely flammable. If fuel mixture or gasoline make contact with open fire or hot objects, they can cause a fire or explosions. Persons may be seriously or fatally injured and property may be damaged.
 - ▶ Protect fuel mixture and gasoline from heat and fire.
 - ▶ Do not spill mixed fuel or gasoline.
 - ▶ If fuel has been spilled: Wipe up fuel with a cloth and do not attempt to start engine until all parts of the chainsaw are dry.
 - ▶ Do not smoke.
 - ▶ Never refuel near a fire.
 - ▶ Shut off the engine and allow it to cool down before refueling.
 - ▶ Start the engine at least 3 meters from the fueling spot, outdoors only.
- Inhaling fuel fumes and gasoline fumes can have toxic effects.
 - ▶ Avoid inhaling fuel fumes or gasoline fumes.
 - ▶ Refuel in a well-ventilated location.
- The chainsaw will become hot during operation, or in a very hot environment. Depending on the type of fuel, altitude, ambient temperature and the temperature of the saw, the fuel expands and can cause a build-up of pressure in the tank. Fuel may spray out and ignite when the fuel tank cap is opened. The user may be seriously injured and property damage may occur.
 - ▶ Allow the chainsaw to cool down before opening the fuel tank cap.
 - ▶ Open the fuel tank cap slowly and not all at once.
- Clothing that has been in contact with fuel or gasoline will become more easy to ignite. Persons may be seriously or fatally injured and property may be damaged.
 - ▶ If your clothing comes into contact with fuel or gasoline: Change your clothing.
- Fuel mix, gasoline and two-stroke engine oil can harm the environment.
 - ▶ Do not spill fuel, gasoline or two-stroke engine oil.
 - ▶ Dispose of fuel mix, gasoline and two-stroke engine oil in accordance with local regulations and environmental requirements.

- Fuel, gasoline or two-stroke engine oil can cause irritation if they come into direct contact with the skin or eyes.
 - ▶ Avoid contact with fuel, gasoline and two-stroke engine oil.
 - ▶ If skin contact occurs: Wash affected areas of skin with plenty of water and soap.
 - ▶ If eye contact occurs: Flush eyes with plenty of water for at least 15 minutes and consult a doctor.
- The ignition system of the chainsaw generates sparks. Unconfined sparks may cause a fire or an explosion in an easily combustible or explosive environment. Persons may be seriously or fatally injured and property may be damaged.
 - ▶ Use the spark plugs described in this instruction manual.
 - ▶ Insert and tighten down the spark plug.
 - ▶ Connect the spark plug boot and press it down firmly.
- The saw can be damaged if it is run on a mixture of fuel which includes unsuitable gasoline or unsuitable two-stroke engine oil, or if an incorrect mix ratio of gasoline and two-stroke engine oil is used.
 - ▶ Mix the fuel as described in this instruction manual.
- The mixture of gasoline and two-stroke engine oil can separate or age if it is stored for a long period. The chainsaw can be damaged if it is used with a fuel mix that has separated or has aged.
 - ▶ Before refueling the saw: Thoroughly mix the fuel.
 - ▶ Use a mixture of gasoline and two-stroke engine oil that is not older than 30 days (STIHL MotoMix: 5 years).
- In certain situations, the user may no longer be able to concentrate on their work. The user may lose control of the chain saw and may trip, fall and be seriously injured.
 - ▶ Work calmly and methodically.
 - ▶ If light and visibility are poor: Do not use your saw.
 - ▶ Use the chain saw on your own.
 - ▶ Do not work above shoulder height.
 - ▶ Watch out for obstacles.
 - ▶ If you start feeling fatigue: Take a break.
- When working up in a tree, the chain saw may fall to the ground. This may result in serious injury to people and damage to property.
 - ▶ Secure chainsaw with a chainsaw stop installed using the ring. Chainsaw stop must be equipped with overload protection. Suitable accessories are available from authorized dealers
- Exhaust gas is produced when the engine is running. Breathing in exhaust gas can have toxic effects. Breathing in exhaust gas can have toxic effects.
 - ▶ Avoid inhaling exhaust gas.
 - ▶ Operate the chainsaw in a well ventilated location.
 - ▶ In the event of nausea, headache, visual disturbances, problems with hearing or dizziness: Stop work and seek medical advice.
- The user's ability to hear and assess noises is restricted when wearing hearing protection with the engine running.
 - ▶ Work calmly and methodically.
- The user will not be able to control the chainsaw properly if it is operated with the Master Control Lever in position . This may result in serious injury to the user.
 - ▶ Check that the Master Control Lever is in position **I** during operation.
 - ▶ Start the engine as described in this User Manual.
- Do not accelerate the engine with the chain brake engaged since this can damage the chain brake.
 - ▶ Disengage the chain brake before you start cutting.
- The moving saw chain can cut the user. This may result in serious injury to the user.
 - ▶ Do not touch the rotating saw chain.
 - ▶ If the saw chain is blocked by an object: Shut off the engine and engage the chain brake. Only then remove the object.
- The moving saw chain warms up and expands. If the saw chain is not sufficiently lubricated and retensioned, the saw chain may

4.8 Working

4.8.1 Sawing

▲ WARNING

- Always work within calling distance of others so that you can summon help in an emergency.
 - ▶ Make sure that people are within earshot outside the working area.
- If the engine is not started properly, the user may lose control of the chainsaw. This may result in serious injury to the user.
 - ▶ Start the engine as described in this User Manual.
 - ▶ If the saw chain is touching the ground or objects: Do not start the engine.

jump off the guide bar or it may break. This may result in serious injury to people and damage to property.

- ▶ Use saw chain lubricant.
- ▶ Check oil level in tank regularly during cutting work. Before the oil tank runs empty: Fill up with saw chain oil.
- ▶ Check the saw chain tension regularly while working. If saw chain tension is insufficient: Tension the saw chain.
- If the chain saw starts behaving differently or in an unusual way while operating, the chain saw may be in an unsafe condition. This may result in serious injury to people and damage to property.
 - ▶ Stop work and consult a STIHL servicing dealer.
- The chain saw may cause vibrations in operation.
 - ▶ Wear gloves.
 - ▶ Take breaks.
 - ▶ If signs of a circulatory disturbance occur: Consult a doctor.
- If the moving saw chain hits a hard object, sparks may occur. Sparks can cause fires in a flammable environment. Persons may be seriously or fatally injured, and property may be damaged.
 - ▶ Do not use in a flammable environment.
- Note that the saw chain continues to rotate for a short period after you release the throttle trigger. People may be cut by the moving saw chain. Persons may be seriously injured.
 - ▶ Wait for the saw chain to stop moving.

▲ WARNING

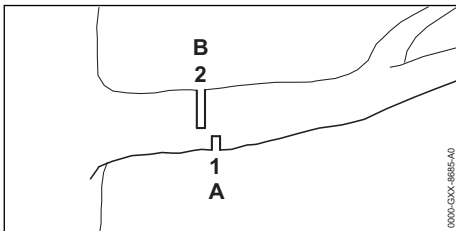

- If you saw wood which is under tension, the guide bar may become jammed. The user may lose control of the chain saw and be seriously injured.
 - ▶ First make a relief cut (1) on the compression side (A), then a separating cut (2), offset in the direction of the trunk, on the tension side (B).

4.8.2 Felling

▲ WARNING

- Inexperienced users cannot assess the dangers of felling a tree. This can result in serious or fatal injuries and damage to property.
 - ▶ If you have any queries: Do not fell the tree yourself.
- Parts of the tree being removed and branches can fall on bystanders or objects during the felling operation. This can result in serious or fatal injuries and damage to property.
 - ▶ Determine direction of fall so that the area in which the part of the tree being removed falls is clear.
 - ▶ Do not allow bystanders, children or animals within 2.5 tree lengths of the work area.

4.9 Reactive Forces

4.9.1 Kickback

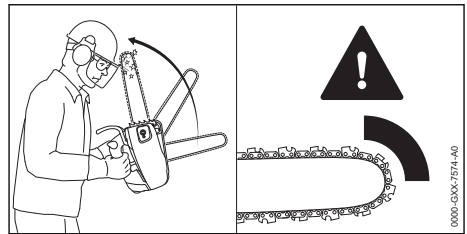

Kickback can be caused for the following reasons:

- The rotating saw chain in the upper quadrant of the bar nose makes contact with a hard object and is suddenly braked.
- The rotating saw chain is pinched at the bar nose.

The chain brake cannot prevent kickback.

▲ WARNING

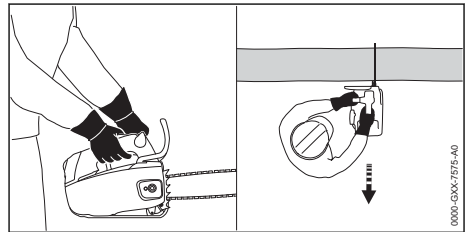

- If kickback occurs, the saw can be thrown up in the direction of the operator. Due to the special handle design (closely spaced handles) there is a risk of the operator losing control of

the chainsaw and sustaining serious or fatal injuries.



- ▶ Hold the saw firmly with both hands.

- ▶ Hold the saw firmly with both hands.
- ▶ Always keep your body out of the plane of the cutting attachment.
- ▶ Use the working techniques described in this instruction manual.
- ▶ Do not cut with the upper quadrant of the bar nose.
- ▶ Always cut with a properly sharpened and tensioned saw chain.
- ▶ Use a reduced kickback saw chain.
- ▶ Use a guide bar with a narrow radius nose.
- ▶ Always cut with the chain running at full speed.

4.9.2 Pull-in

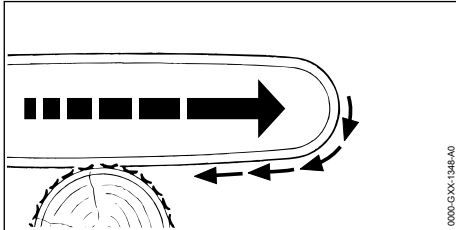

The saw is pulled away from the operator when the bottom of the bar is used for cutting.

▲ WARNING

- If the rotating chain makes contact with a hard object and is suddenly pinched, the saw is abruptly jerked away from the operator. The operator can lose control of the saw and be seriously or fatally injured.
 - ▶ Hold the saw firmly with both hands.
 - ▶ Operate the saw as described in this instruction manual.
 - ▶ Keep the guide bar straight in the cut.
 - ▶ Apply the spiked bumper properly.
 - ▶ Always cut with the chain running at full speed.

4.9.3 Pushback

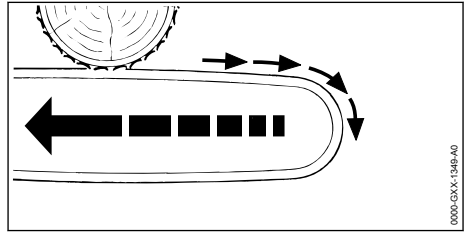

The saw is pushed back toward the operator when the top of the bar is used for cutting.

▲ WARNING

- If the rotating chain makes contact with a hard object and is suddenly pinched, the saw can be abruptly pushed back toward the operator. The operator can lose control of the saw and be seriously or fatally injured.
 - ▶ Hold the saw firmly with both hands.
 - ▶ Operate the saw as described in this instruction manual.
 - ▶ Keep the guide bar straight in the cut.
 - ▶ Always cut with the chain running at full speed.

4.10 Transporting

▲ WARNING

- The saw may turn over or shift during transport. This can result in serious injuries and damage to property.
 - ▶ Shut off the engine.
 - ▶ Engage the chain brake.
 - ▶ Fit the scabbard so that it completely covers the guide bar.
 - ▶ Secure the chainsaw with lashing straps, belts or a net to prevent it turning over and moving.

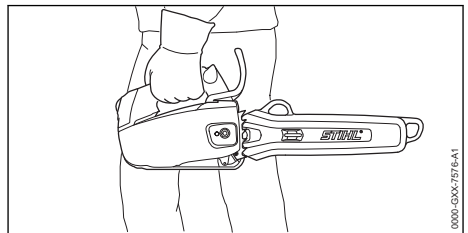

- The muffler and engine may be hot after a period of operation. There is a risk of burn injuries.
 - ▶ Carry the saw by holding the top handle in your left hand with the guide bar pointing to the rear.

4.11 Storing

▲ WARNING

- Children are not aware of and cannot assess the dangers of a chainsaw and can be seriously injured.
 - ▶ Shut off the engine.
 - ▶ Engage the chain brake.
 - ▶ Fit the scabbard so that it completely covers the guide bar.
 - ▶ Store the saw out of the reach of children.
- Dampness can corrode the electrical contacts on the saw and metal components. This can damage the saw.
 - ▶ Store the saw in a clean and dry condition.

4.12 Cleaning, Maintenance and Repair

▲ WARNING











- The saw chain can start up unintentionally if the engine is running during cleaning, maintenance or repair operations. This may result in serious injury to people and damage to property.
 - ▶ Shut off the engine.
 - ▶ Engage the chain brake.
- The muffler and engine may be hot after a period of operation. This can result in burn injuries.
 - ▶ Wait until the muffler and engine cool down.
- Aggressive cleaning agents, a water jet or pointed objects can damage the chainsaw, guide bar and saw chain. If the chainsaw, guide bar or saw chain are not cleaned correctly, components may no longer function properly or safety devices may be rendered inoperative. They may cause serious injury to persons.
 - ▶ Clean the chainsaw, guide bar and saw chain as described in this user manual.
- If the chainsaw is not maintained as described in this user manual, components may no longer function properly or safety devices may be rendered inoperative. This may result in serious or fatal injury to people.
 - ▶ Service or repair the chainsaw as described in this user manual.
- If the guide bar and saw chain are not maintained or repaired as described in this user manual, components may no longer function properly or safety devices may be rendered inoperative. They may cause serious injury to persons.

- ▶ Service or repair the guide bar and saw chain as described in this User Manual.
- The user may be cut by the sharp cutters while cleaning or servicing the saw chain. This may result in injury to the user.
 - ▶ Wear work gloves made from resistant material.

5 Preparing the Saw for Operation

5.1 Preparing the Saw for Operation

Perform the following steps before starting work:

- ▶ Make sure the following components are in a safe condition:
 - Chainsaw,  4.6.1.
 - Guide bar,  4.6.2.
 - Saw chain,  4.6.3.
- ▶ Clean the saw,  15.1.
- ▶ Mount the bar and chain,  6.1.1.
- ▶ Tension the saw chain,  6.2.
- ▶ Fill up with chain oil,  6.3.
- ▶ Check the chain brake,  10.4.
- ▶ Refuel the saw,  8.2.
- ▶ Check the controls,  10.5.
- ▶ Check chain lubrication,  10.6.
- ▶ If you cannot carry out these steps: Do not use your chainsaw and contact your STIHL servicing dealer for assistance.

6 Assembling the Saw

6.1 Mounting and Removing the Bar and Chain

6.1.1 Mounting the bar and chain

The bar and chain combinations that can be used with the chain sprocket are listed in the specifications,  20.1.

- ▶ Shut off the engine and engage the chain brake.

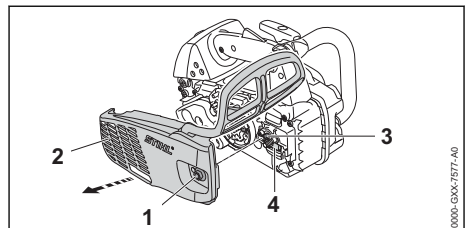

- ▶ Rotate the nut (1) counterclockwise until the chain sprocket cover (2) can be removed.
- ▶ Remove the chain sprocket cover (2).

- ▶ Turn the tensioning screw (3) counterclockwise until the tensioner slide (4) butts against the left end of the housing.

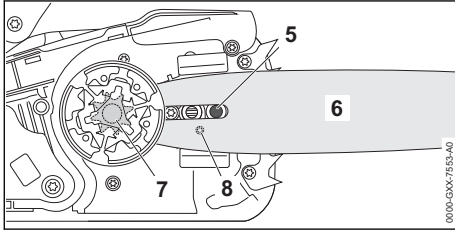

- ▶ Fit the guide bar and chain on the saw and check the following points:
 - Collar stud (5) is located in slot in tail of guide bar (6).
 - Peg of tensioner slide (4) engages hole (8) in guide bar (6).

The guide bar (6) may be either way round. The logo on the guide bar (6) may also be upside down.

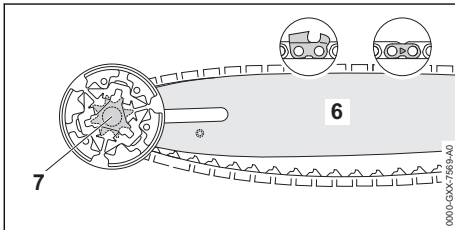

- ▶ Fit the chain on the chain sprocket (7) so that the chain's drive links mesh with the sprocket's teeth.
- ▶ Fit the chain in the bar groove so that the arrows on the tie straps on the top of the bar point in the direction of rotation.

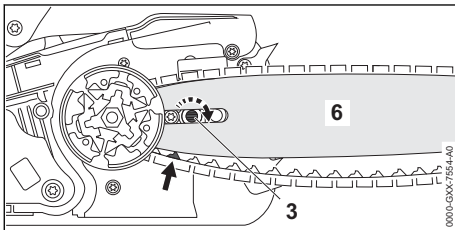

- ▶ Turn the tensioning screw (3) clockwise until the chain fits snugly against the bar. Make sure the drive link tangs engage the bar groove. The guide bar (6) and chain are seated against the saw.

- ▶ Fit the sprocket cover (2) so that it is flush with the saw.
- ▶ Fit and tighten down the nut (1).

6.1.2 Removing the bar and chain

- ▶ Shut off the engine and engage the chain brake.
- ▶ Rotate the nut counterclockwise until the chain sprocket cover can be removed.
- ▶ Remove the sprocket cover.
- ▶ Turn the tensioning screw counterclockwise as far as stop. The chain is now slack.
- ▶ Remove the bar and chain.

6.2 Tensioning the Saw Chain

The saw chain expands or contracts during cutting work. Chain tension changes as a result. Check chain tension regularly during operation and readjust if necessary.

- ▶ Shut off the engine and engage the chain brake.

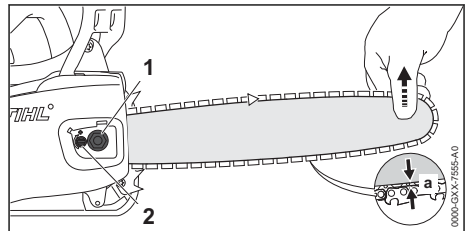

- ▶ Loosen the nut (1).
- ▶ Disengage the chain brake.
- ▶ Hold the bar nose up and turn the tensioning screw (2) clockwise until the following points apply:
 - Chain sag 'a' in the center of the bar is 1 - 2 mm.
 - The chain can still be pulled easily along the bar with two fingers.
- ▶ Keep holding the bar nose up and tighten down the nut (1) firmly.
- ▶ If chain sag 'a' in the center of the bar is not 1 - 2 mm: Readjust chain tension.

6.3 Filling Up with Saw Chain Oil

The saw chain oil lubricates and cools the rotating chain.

STIHL recommends you use a STIHL saw chain oil or an equivalent chain oil approved for chainsaws.

- ▶ Shut off the engine and engage the chain brake.

- ▶ Place your chainsaw on a level surface so that the oil tank cap faces up.
- ▶ Use a damp cloth to clean the oil tank cap and the area around it.

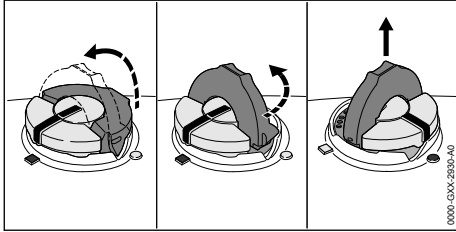

- ▶ Swing the grip on the oil tank cap to the vertical position.
- ▶ Turn the oil tank cap counterclockwise as far as it will go.
- ▶ Remove the oil tank cap.
- ▶ Fill up with saw chain oil, taking care not to spill any oil and not to overfill the tank.
- ▶ If the grip on the oil tank cap has dropped into the closed position: Raise the grip until it is vertical.

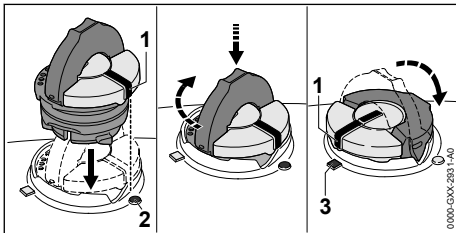

- ▶ Place the oil tank cap in the filler opening so that mark (1) lines up with mark (2).
- ▶ Press the oil tank cap down and rotate it clockwise as far as it will go. The oil tank cap snaps into place. The mark (1) points to mark (3).
- ▶ Check to see if the oil tank cap can be pulled upwards and off.
- ▶ If the oil tank cap cannot be pulled upwards and off: Fold down the grip on the oil tank cap. The oil tank is closed.

If the oil tank cap can be pulled upwards and off, perform the following steps:

- ▶ Place the oil tank cap in the filler opening – in any position.

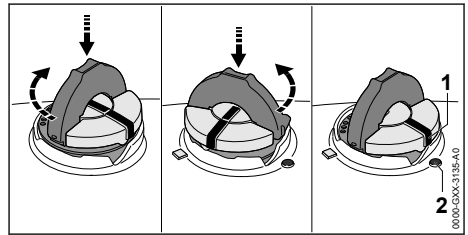

- ▶ Press the oil tank cap down and rotate it clockwise as far as it will go.
- ▶ Press the oil tank cap down and rotate it counterclockwise until mark (1) points to mark (2).
- ▶ Now try again to close the oil tank.
- ▶ If the oil tank still cannot be closed properly: Do not use the chainsaw and contact a STIHL dealer for assistance. The chainsaw is not in a safe condition.

7 Engaging and Disengaging the Chain Brake

7.1 Engaging the Chain Brake

The saw is equipped with a chain brake.

The chain brake is activated by the inertia of the front hand guard if the kickback force is high enough or it can be engaged by the operator.

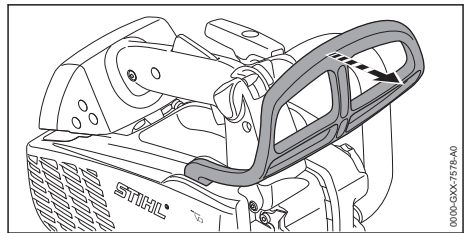

- ▶ Push the hand guard away from the handlebar with your left hand. The hand guard engages with an audible click. The chain brake is engaged.

7.2 Disengaging the Chain Brake

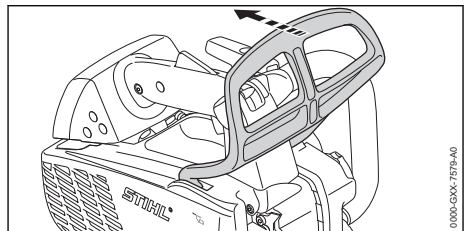

- ▶ Pull the hand guard back towards the handle with your left hand.
The hand guard engages with an audible click.
The chain brake is disengaged.

8 Mixing Fuel and Refueling the Chainsaw

8.1 Mixing fuel

The fuel required for this chainsaw is a mixture of two-stroke engine oil and gasoline, in a mixing ratio of 1:50.

STIHL recommends you use STIHL MotoMix.

If you mix the fuel yourself, use only STIHL two-stroke engine oil or another high-performance engine oil in accordance with JASO FB, JASO FC, JASO FD, ISO-L-EGB, ISO-L-EGC or ISO-L-EGD.

STIHL specifies STIHL HP Ultra two-stroke engine oil or an equivalent high-performance engine oil in order to maintain emission limits over the machine's service life.

- ▶ Make sure that the octane number of the gasoline is at least 90 RON and the ethanol content is not more than 10% (for Brazil: 27%).
- ▶ Make sure the two-stroke engine oil you are using meets the requirements.
- ▶ Depending on the desired amount of fuel, determine the correct amounts of two-stroke engine oil and gasoline in a mixing ratio of 1:50. Examples for fuel mixes:
 - 20 ml Two-stroke engine oil, 1 l gasoline
 - 60 ml Two-stroke engine oil, 3 l gasoline
 - 100 ml Two-stroke engine oil, 5 l gasoline
- ▶ Pour two-stroke engine oil into a clean approved fuel canister first and then add gasoline.
- ▶ Thoroughly mix the fuel before topping up.

8.2 Filling up the Chainsaw with Fuel

- ▶ Shut off the engine and engage the chain brake.
- ▶ Allow the chainsaw to cool down.
- ▶ Place your chainsaw on a level surface so that the fuel tank cap faces up.
- ▶ Use a damp cloth to clean the fuel tank cap and the area around it.
- ▶ Fold out the handle on the fuel tank cap.

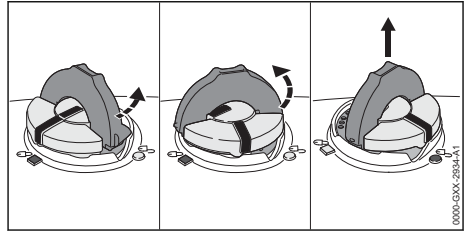

! WARNING

- The chainsaw will become hot during operation, or in a very hot environment. Depending on the type of fuel, altitude, ambient temperature and the temperature of the saw, the fuel expands and can cause a build-up of pressure in the tank. Fuel may spray out and ignite when the fuel tank cap is opened. The user may be seriously injured and property damage may occur.
 - ▶ Allow the chainsaw to cool down before opening the fuel tank cap.
 - ▶ Open the fuel tank cap slowly and not all at once.
- ▶ Turn the fuel tank cap about 1/8-of-a-turn counterclockwise.
If the fuel tank is under pressure, you will hear the overpressure being released.
- ▶ When the tank is no longer under pressure: Turn the fuel tank cap counterclockwise until the marks on the cap and fuel tank are in alignment.
- ▶ Remove the fuel tank cap.

NOTICE

- Exposure to light, direct sunlight and extreme temperatures may accelerate fuel separation or aging. Topping the chainsaw up with unmixed or older fuel may damage the chainsaw.
 - ▶ Thoroughly mix the fuel before topping up.
 - ▶ Do not top up with fuel stored for more than 30 days (STIHL MotoMix: 5 years).
- ▶ When topping up, ensure that no fuel is spilled and that the fuel level remains at least 15 mm under the edge of the tank.
- ▶ If the handle on the fuel tank cap has dropped into the closed position: Fold out the handle.

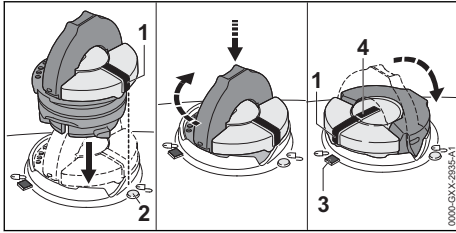

- ▶ Place the fuel tank cap in the filler opening so that mark (1) lines up with mark (2).
- ▶ Press the fuel tank cap down and rotate it clockwise until it stops.
The fuel tank cap snaps into place. Mark (1) is in line with mark (4) and points to mark (3).
- ▶ Check to see if the fuel tank cap can be pulled up and off.
- ▶ If the fuel tank cap cannot be pulled up and off: Fold the handle flat to the top of the cap. The fuel tank is closed.

If the fuel tank cap can be pulled up and off, perform the following steps:

- ▶ Place the fuel tank cap in the filler opening – in any position.

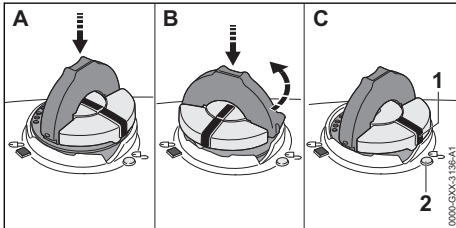

- ▶ Press the fuel tank cap down and rotate it clockwise until it stops.
- ▶ Press the cap down and rotate it counterclockwise until mark (1) points to mark (2).
- ▶ Now try again to close the fuel tank.
- ▶ If the fuel tank still cannot be closed properly: Do not use the chainsaw and contact a STIHL dealer for assistance.
The chainsaw is not in a safe condition.

9 Starting and Stopping the Engine

9.1 Selecting the correct starting procedure

When must the engine be prepared for starting?

The engine must be prepared for starting if one of the following conditions apply:

- The engine is at ambient temperature.

- The engine stopped when accelerated for the first time.
- The engine stopped because the fuel tank was empty.
- ▶ Prepare engine for start, 9.2 and then start the engine, 9.3.

When can the engine be started without preparation?

The engine can be started without preparation if it has been running for at least 1 minute and only shut down for a short work break.

- ▶ Starting the engine, 9.3.

9.2 Preparing Engine for Start

- ▶ Select the correct starting procedure.

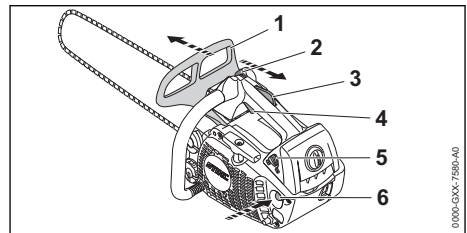

- ▶ Engage the chain brake (1).
- ▶ Pull off the chain guard (scabbard).
- ▶ Press the manual fuel pump bulb (6) at least ten times.
- ▶ Press down the throttle trigger lockout (3) and hold it there.
- ▶ Pull the throttle trigger (4) and hold it there.
- ▶ Move the Master Control lever (2) to position .
- ▶ Release the throttle trigger (4) and lockout lever (5).
- ▶ Move the choke lever (5) to position .

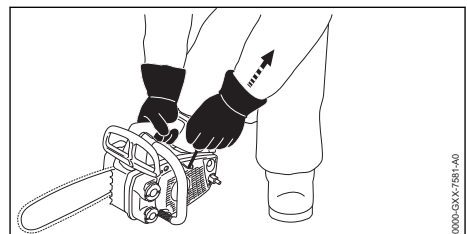

- ▶ Stand the saw on a level surface.
- ▶ Hold the saw firmly with your right hand on the top handle – wrap your thumb around the handle.
- ▶ Press the saw against the ground with your right hand.
- ▶ Hold the saw steady with your right knee on the shroud.

- ▶ Pull the starter grip slowly with your left hand until you feel it engage.
- ▶ Pull the starter grip quickly and allow the starter rope to rewind several times until the engine fires and stops.
- ▶ Move the choke lever (5) to position **III**.

9.3 Starting the Engine

- ▶ Select the correct starting procedure.

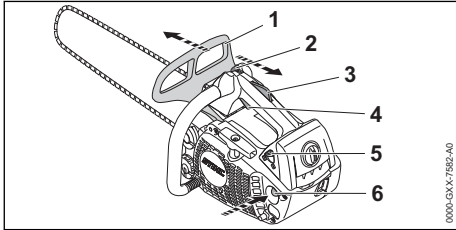

- ▶ Engage the chain brake (1).
- ▶ Pull off the chain guard (scabbard).
- ▶ Move the choke lever (5) to position **III**.
- ▶ Press down the throttle trigger lockout (3) and hold it there.
- ▶ Pull the throttle trigger (4) and hold it there.
- ▶ Move the Master Control lever (2) to position **II**.

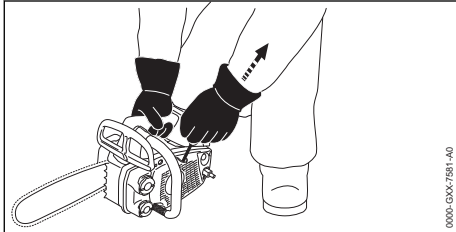

- ▶ Stand the saw on a level surface.
- ▶ Hold the trimmer firmly with your right hand on the top handle – wrap your thumb around the handle.
- ▶ Press the saw against the ground with your right hand.
- ▶ Hold the saw steady with your right knee on the shroud.
- ▶ Pull the starter grip slowly with your left hand until you feel it engage.
- ▶ Pull the starter grip quickly and allow the starter rope to rewind several times until the engine runs.
- ▶ Press down the throttle trigger lockout (3) and hold it there.
- ▶ Blip the throttle trigger (4).
The Master Control lever (2) springs to position **I**. The engine runs at idling speed.

NOTICE

- Do not accelerate the engine with the chain brake engaged since this can damage the chain brake.
 - ▶ Disengage the chain brake before you start cutting.
- ▶ Disengage the chain brake.
Your saw is ready for operation.
- ▶ If the saw chain rotates while the engine is idling: See troubleshooting.
Idle speed adjustment is not correct.
- ▶ If the engine does not start: Prepare the engine for the start and then try again to start the engine.

9.4 Stopping the engine

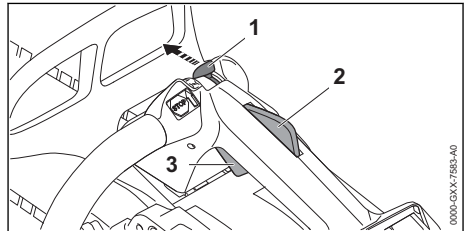

- ▶ Release the throttle trigger (3) and lockout lever (2).
The saw chain stops running.
- ▶ Move the Master Control lever (1) to position **C**.
The engine stops and the Master Control lever (1) springs back to position **I**.
- ▶ If the engine does not stop:
 - ▶ Move the choke lever to position **II**.
The engine stops.
 - ▶ Do not use the chainsaw and contact your STIHL servicing dealer for assistance.
The Master Control lever is defective.

10 Checking the Saw

10.1 Checking the Chain Sprocket

- ▶ Shut off the engine.
- ▶ Disengage the chain brake.
- ▶ Remove the chain sprocket cover.
- ▶ Remove the bar and chain.

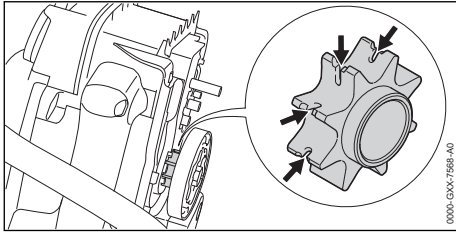

- ▶ If there are visible wear marks: Do not use the chainsaw and contact your STIHL servicing dealer for assistance. The chain sprocket must be replaced.

10.2 Checking the Guide Bar

- ▶ Shut off the engine and engage the chain brake.
- ▶ Remove the chain and guide bar.

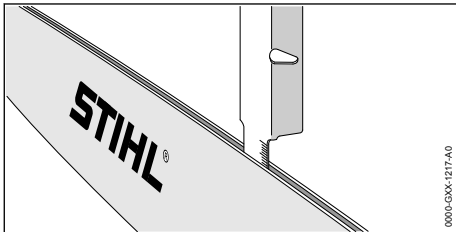

- ▶ Measure depth of bar groove with scale on STIHL filing gauge.
- ▶ Install a new guide bar if one of the following points applies:
 - Guide bar is damaged.
 - Measured bar groove depth is less than specified minimum depth,  19.3.
 - Bar groove is pinched or splayed.
- ▶ If you have any queries: Contact your STIHL servicing dealer for assistance.

10.3 Checking the Saw Chain

- ▶ Shut off the engine and engage the chain brake.

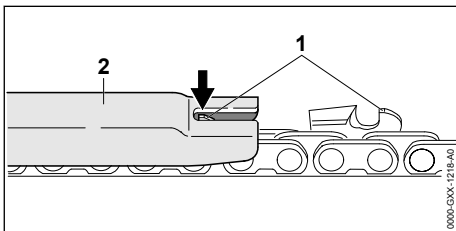

- ▶ Use a STIHL filing gauge (2) to check the height of the depth gauges (1). The STIHL filing gauge must match the chain pitch.

- ▶ If a depth gauge (1) projects from the filing gauge (2): Lower the depth gauge (1),  16.3.

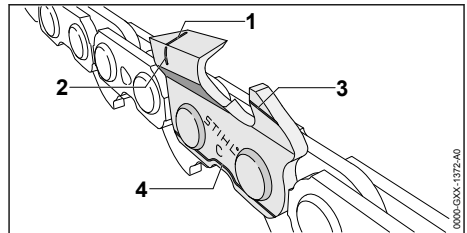

- ▶ Make sure the service marks (1 to 4) on the cutters are visible.
- ▶ If one of the service marks is not visible on a cutter: Do not use your chainsaw and contact your STIHL servicing dealer for assistance.
- ▶ Use a STIHL filing gauge to check that a filing angle of 30° has been maintained on all cutters. The STIHL filing gauge must match the chain pitch.
- ▶ If a filing angle of 30° has not been maintained: Resharpen the saw chain.
- ▶ If you have any queries: Contact your STIHL servicing dealer for assistance.

10.4 Testing the Chain Brake

- ▶ Shut off the engine and engage the chain brake.

 **WARNING**

- The chain's cutters are very sharp. There is a risk of cut injuries.
 - ▶ Wear work gloves made of durable material.

- ▶ Try to pull the chain along the guide bar by hand. If the chain cannot be pulled along the bar by hand, the chain brake is functioning.
- ▶ If the chain can be pulled along the bar by hand: Do not use your chainsaw and contact your STIHL servicing dealer for assistance. The chain brake is defective.

10.5 Checking the Controls

Throttle trigger lockout and throttle trigger

- ▶ Shut off the engine and engage the chain brake.
- ▶ Attempt to pull the trigger without depressing the lockout lever.
- ▶ If the trigger can be pulled: Do not use the chainsaw and contact your STIHL servicing dealer for assistance. The throttle trigger lockout is defective.

- ▶ Press down the throttle trigger lockout and hold it there.
- ▶ Pull the throttle trigger and release it again.
- ▶ If the throttle trigger is stiff or does not spring back to its idle position: Do not use the chainsaw and contact your STIHL servicing dealer for assistance.
The throttle trigger is defective.

Stopping the engine

- ▶ Start the engine.
- ▶ Move the Master Control lever (1) to position **C**.
The engine stops and the Master Control lever springs back to position **I**.
- ▶ If the engine does not stop:
 - ▶ Move the choke lever to position **II**.
The engine stops.
 - ▶ Do not use the chainsaw and contact your STIHL servicing dealer for assistance.
The Master Control lever is defective.

10.6 Checking Chain Lubrication

- ▶ Start the engine and disengage the chain brake.
- ▶ Hold the guide bar over a light surface.
- ▶ Open the throttle.
Chain oil is thrown off the chain and is visible on the light surface. Chain lubrication is operating properly.
- ▶ If no chain oil can be seen:
 - ▶ Shut off the engine.
 - ▶ Fill up with chain oil.
 - ▶ Check chain lubrication again.
 - ▶ If chain oil is still not visible on the light surface: Do not use your chainsaw and contact your STIHL servicing dealer for assistance.
Chain lubrication is defective.

11 Operating the Saw

11.1 Adjusting Carburetor for Operation at High Altitude

If you use the chainsaw at high altitude, the engine will not deliver optimum power. The carburetor setting can be adjusted to obtain optimum engine power.

- ▶ Start the engine and disengage the chain brake.
- ▶ Warm up the engine by opening and closing the throttle for about 1 minute.

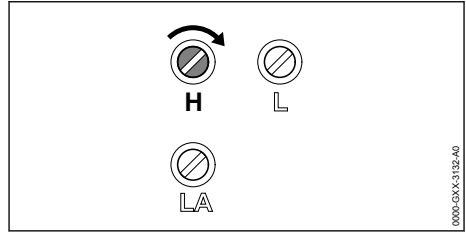

NOTICE

- If the chainsaw is again used at a low altitude, the engine may overheat.
 - ▶ Carry out the standard setting.
- ▶ Rotate the high speed screw H clockwise until the engine delivers optimum power.

11.2 Adjusting Carburetor for Cutting at Temperatures Below –10°C

The engine will not accelerate properly if the chainsaw is used at temperatures below –10°C. The carburetor can be adjusted to obtain normal engine acceleration in such conditions.

- ▶ Start the engine and disengage the chain brake.
- ▶ Warm up the engine by opening and closing the throttle for about 1 minute.

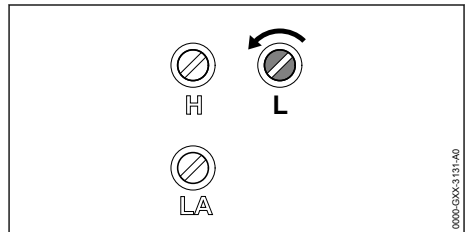

NOTICE

- Engine power may drop noticeably when the chainsaw is subsequently used at temperatures above –10°C.
 - ▶ Carry out the standard setting.
- ▶ Rotate the low speed screw (L) a quarter turn counterclockwise.
- ▶ If the saw chain runs continuously or the engine stops: Adjust idle speed.

11.3 Holding and Controlling the Chainsaw

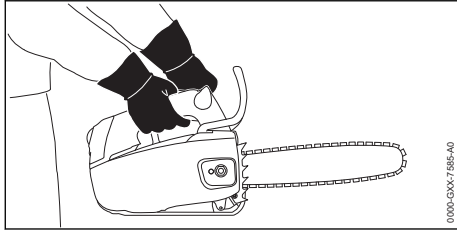

- ▶ Hold and control your saw with your left hand on the handlebar and your right hand on the top handle. Wrap thumb of left hand around the handlebar and thumb of right hand around the top handle.

! WARNING

- The risk of kickback is increased if you use the chainsaw with one hand. If kickback occurs, the saw can be thrown up in the direction of the operator. The operator can lose control of the saw and be seriously or fatally injured.
 - ▶ Do not cut with the upper quadrant of the bar nose.
 - ▶ Never support yourself on the limb being cut.
 - ▶ Never attempt to hold falling limbs.

The saw may be used with one hand if the following points apply:

- Two-handed cutting is not possible.
- One hand is required for support during the cut.
- The saw can be held firmly with one hand.
- All parts of your body are clear of the cutting attachment.

11.4 Cutting

! WARNING

- If kickback occurs, the saw can be thrown up in the direction of the operator. This can result in serious or fatal injuries.
 - ▶ Always cut with the chain running at full speed.
 - ▶ Do not cut with the upper quadrant of the bar nose.
- ▶ Begin the cut with the chain running at full speed and keep the guide bar vertical.

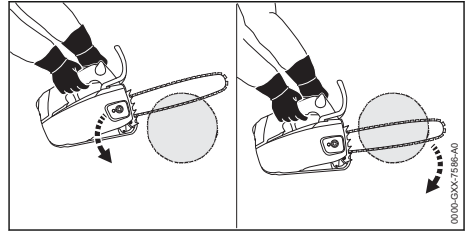

- ▶ Engage the spiked bumper and use it as a fulcrum.
- ▶ Guide the full width of the bar into the wood and reposition the spiked bumper as required.
- ▶ Take the weight of the saw at the end of the cut.

11.5 Limbing

- ▶ With the chain running at full speed, pivot the guide bar downward against the limb.

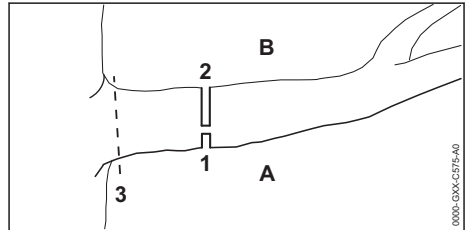

- ▶ Make a relieving cut (1) in the compression side (A) first, then perform a bucking (2) cut at the tension side (B) from above, directly above the first cut.
- ▶ Make the last cut (3) close to the trunk without damaging the bark.

11.6 Felling

11.6.1 Basic information on felling cut

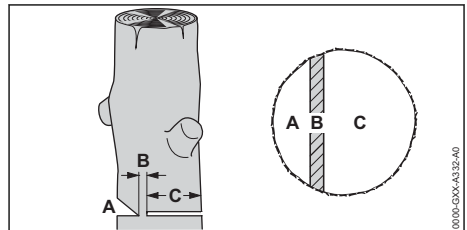

A Felling notch

The felling notch determines the direction of fall.

B Hinge

The hinge controls the part of the tree being removed as it drops to the ground. The width of the hinge is 1/10 of the trunk diameter.

C Felling cut

The tree is felled with the felling cut.

11.6.2 Cutting the felling notch

The felling notch determines the direction in which the part of the tree being removed falls. Country-specific standards for making the felling notch must be observed.

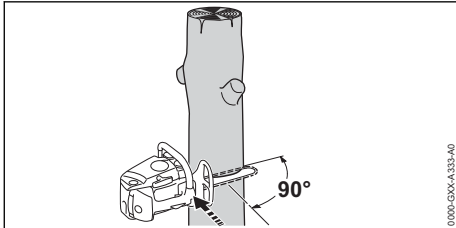

- ▶ Position the saw so that the felling notch is at right angles to the direction of fall.
- ▶ Make the horizontal cut.
- ▶ Make the angle cut at 45° to the horizontal cut.

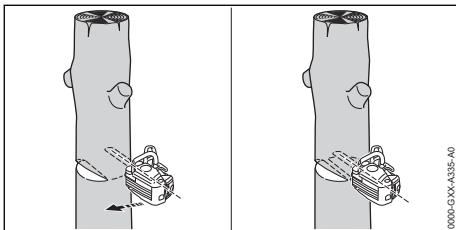
11.6.3 Making the felling cut

- ▶ Make horizontal felling cut, taking care not to cut through the hinge.
- ▶ Shout a warning.
- ▶ Push the part of the tree being removed downward over the hinge.
The part of the tree to be removed falls.

12 After Finishing Work**12.1 After Finishing Work**

- ▶ Shut off the engine and engage the chain brake.
- ▶ Allow chainsaw to cool down.
- ▶ If the saw is wet: Allow the saw to dry.
- ▶ Clean the saw.
- ▶ Clean the air filter.
- ▶ Clean the bar and chain.
- ▶ Loosen nut on the chain sprocket cover.

- ▶ Turn the tensioning screw two full turns counterclockwise.
The chain is now slack.
- ▶ Tighten down the nut on the chain sprocket cover.
- ▶ Fit the scabbard so that it completely covers the guide bar.

13 Transporting**13.1 Transporting the Chainsaw**

- ▶ Shut off the engine and engage the chain brake.
- ▶ Push the chain scabbard over the guide bar so that it completely covers the guide bar.

Carrying the Chainsaw

- ▶ Carry the chainsaw by holding the control handle in your left hand with the guide bar pointing to the rear.

Transporting the Chainsaw in a Vehicle

- ▶ Secure the saw to prevent turnover and movement.

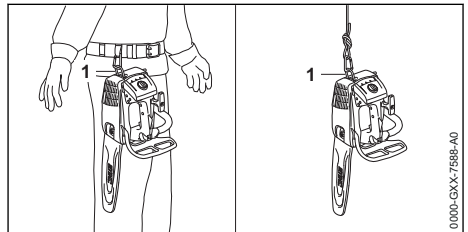
Motorsäge an einer Öse transportieren

- ▶ Transport the chainsaw using the ring (1) on the belt or on a rope.

14 Storing**14.1 Storing the Chainsaw**

- ▶ Shut off the engine and engage the chain brake.
- ▶ Fit the chain scabbard so that it completely covers the guide bar.
- ▶ Observe the following points when storing the chainsaw:
 - Chainsaw is out of reach of children.
 - The chainsaw is clean and dry.

- ▶ If you store the chainsaw for more than 30 days:
 - ▶ Remove the guide bar and saw chain.
 - ▶ Open the fuel tank cap.
 - ▶ Drain the fuel tank.
 - ▶ Close the fuel tank.
 - ▶ If a manual fuel pump is fitted: Press the manual fuel pump at least 5 times.
 - ▶ Start the engine and run it at idling speed until it stops.

15 Cleaning

15.1 Cleaning the Saw

- ▶ Shut off the engine and engage the chain brake.
- ▶ Allow chainsaw to cool down.
- ▶ Clean the saw with a damp cloth or STIHL resin solvent.
- ▶ Clean cooling air slots with a soft brush.

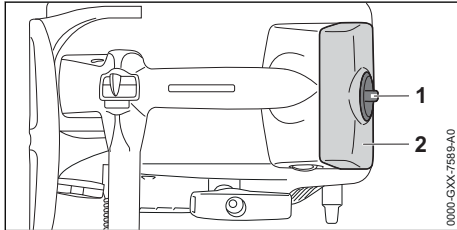

- ▶ Rotate the shroud lock (1) a half turn counterclockwise.
- ▶ Remove the shroud (2).
- ▶ Remove the chain sprocket cover.
- ▶ Use a soft brush, damp cloth or STIHL resin solvent to clean the inside of the shroud.
- ▶ Clean the area around the sprocket with a damp cloth or STIHL resin solvent.
- ▶ Place the shroud (2) in position.
- ▶ Rotate the shroud lock (1) clockwise until you hear a click.
The shroud lock (1) is secure.
- ▶ Fit the chain sprocket cover.

15.2 Cleaning the Bar and Chain

- ▶ Shut off the engine and engage the chain brake.
- ▶ Remove the bar and chain.

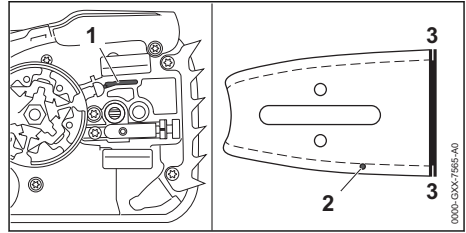

- ▶ Clean the oil inlet hole (1), oil port (2) and bar groove (3) with a soft brush or STIHL resin solvent.
- ▶ Clean the saw chain with a soft brush or STIHL resin solvent.
- ▶ Mount the bar and chain.

15.3 Cleaning the Spark Plug

- ▶ Shut off the engine and engage the chain brake.
- ▶ Allow the chainsaw to cool down.

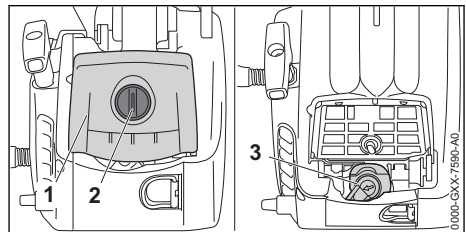

- ▶ Turn the cover lock (2) counterclockwise 1/2 turn.
- ▶ Remove cover (1).
- ▶ Pull off the spark plug boot (3).
- ▶ If the area around the spark plug is soiled: Clean it with a cloth.
- ▶ Unscrew the spark plug.
- ▶ Clean the spark plug with a cloth.
- ▶ If the spark plug is corroded: Replace the spark plug.

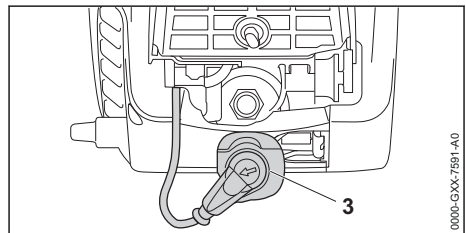

- ▶ Insert and tighten down the spark plug.
- ▶ Press the spark plug boot (3) firmly home.
- ▶ Fit the cover (1).

- ▶ Rotate the shroud lock (2) clockwise until you hear a click.
The cover lock (2) is secure.

15.4 Cleaning the Air Filter

15.4.1 Cleaning the fabric air filter

- ▶ Shut off the engine and engage the chain brake.

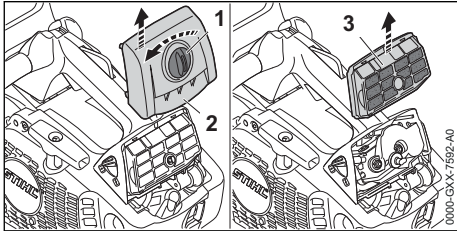

- ▶ Rotate the shroud lock (1) a half turn counter-clockwise.
- ▶ Remove the shroud (2).
- ▶ Remove the air filter (3).
- ▶ Knock out the filter (3).
- ▶ Clean the filter (3) with a soft brush.
- ▶ If the filter (3) is damaged. Install a new filter (3).
- ▶ Blow out the filter with compressed air from the clean air side.

WARNING

- Cleaning agent may cause irritation if it contacts the skin or eyes.
 - ▶ Observe the information supplied with the cleaning agent.
 - ▶ Avoid contact with cleaning agents.
 - ▶ In case of contact with the skin: Wash affected areas with plenty of water and soap.
 - ▶ In case of contact with the eyes: Rinse eyes with plenty of water for at least 15 minutes and seek medical advice.
- ▶ If the air filter is very dirty:
 - ▶ Wash the filter (3) in STIHL special cleaner or warm soapy water.
 - ▶ Rinse the filter (3) from the clean air side under running water.
 - ▶ Allow filter (3) to dry in the air.

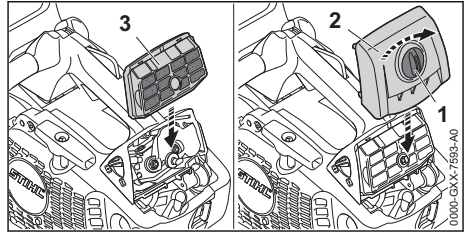

- ▶ Install the filter (3).
- ▶ Place the shroud (2) in position.
- ▶ Rotate the shroud lock (1) clockwise until you hear a click.
The shroud lock (1) is secure.

15.4.2 Cleaning the fleece air filter

- ▶ Shut off the engine and engage the chain brake.

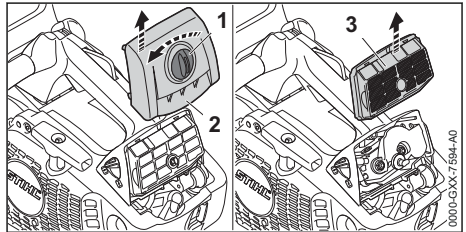

- ▶ Rotate the shroud lock (1) a half turn counter-clockwise.
- ▶ Remove the shroud (2).
- ▶ Remove the air filter (3).
- ▶ Knock out the filter (3).
- ▶ If the filter (3) is damaged. Install a new filter (3).
- ▶ Blow out the filter with compressed air from the clean air side.

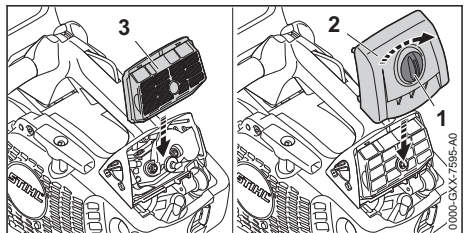

- ▶ Install the filter (3).
- ▶ Place the shroud (2) in position.
- ▶ Rotate the shroud lock (1) clockwise until you hear a click.
The shroud lock (1) is secure.

16 Maintenance

16.1 Maintenance intervals

Maintenance intervals depend on the ambient conditions and the operating conditions. STIHL recommends the following maintenance intervals:

Chain brake

- ▶ Have a STIHL dealer service the chain brake in the following intervals:
 - Full-time use: every three months
 - Part-time use: every six months
 - Occasional use: every year

After every 100 hours of operation

- ▶ Replace the spark plug.

Weekly

- ▶ Check the chain sprocket.
- ▶ Check and deburr the guide bar.
- ▶ Check and resharpen the saw chain.

Monthly

- ▶ Have the oil tank cleaned by a STIHL dealer.
- ▶ Have the fuel tank cleaned by a STIHL dealer.
- ▶ Have the pickup body in the fuel tank cleaned by a STIHL dealer.

Annually

- ▶ Have the pickup body in the fuel tank replaced by a STIHL dealer.

16.2 Deburring the Guide Bar

A burr can build up on the outer edge of the guide bar.

- ▶ Remove burr with a flat file or a STIHL guide bar dressing tool.
- ▶ If you have any queries: Contact your STIHL servicing dealer.

16.3 Sharpening the Saw Chain

Correctly sharpening saw chains requires a lot of practice.

STIHL files, STIHL filing aids, STIHL sharpeners and the brochure "Sharpening STIHL Saw Chains" help you achieve the right results. To obtain the brochure visit <http://www.stihl.com/sharpening-brochure>.

STIHL recommends you have saw chains resharpened by a STIHL servicing dealer.

18 Troubleshooting

18.1 Troubleshooting Chainsaw

Most malfunctions have the same causes.

! WARNING

- The chain's cutters are very sharp. There is a risk of cut injuries.
 - ▶ Wear work gloves made of durable material.

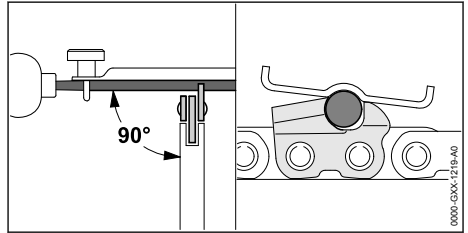

- ▶ File each cutter with a round file so that the following points are observed:
 - Round file matches the chain pitch.
 - File from the inside to the outside of the cutter.
 - Hold the file at right angle to the guide bar.
 - Maintain a filing angle of 30°.

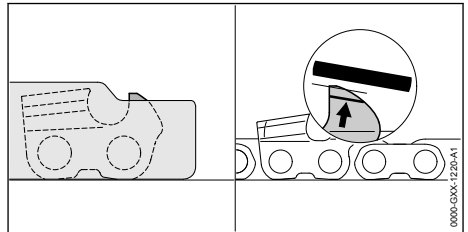

- ▶ File down the depth gauges with a flat file so that they are level with the STIHL filing gauge and parallel to the service mark. The STIHL filing gauge must match the chain pitch.
- ▶ If you have any queries: Contact your STIHL servicing dealer for assistance.

17 Repairing

17.1 Repairing the Chain Saw, Guide Bar and Saw Chain

The chain saw, guide bar and saw chain cannot be repaired by the user.

- ▶ If the saw, guide bar or saw chain is damaged: Do not use your saw, guide bar or saw chain, and contact your STIHL servicing dealer.

- ▶ Perform the following operations:
 - ▶ Clean the air filter.
 - ▶ Clean or replace the spark plug.
 - ▶ Carry out the standard setting.
 - ▶ Adjust idle speed.
 - ▶ Adjust carburetor for operation at high altitude.
 - ▶ Adjust carburetor for cutting at temperatures below -10°C .
- ▶ If the malfunction still exists: Take the action described in the following table.

Condition	Cause	Remedy
Engine does not start.	Insufficient fuel in the tank.	▶ Mix fuel and refuel the chainsaw.
	Engine is flooded.	▶ Clear the combustion chamber.
	Carburetor is too hot.	▶ Allow chainsaw to cool down. ▶ If manual fuel pump is fitted: Depress the manual fuel pump at least 10 times before starting the engine.
	Carburetor is iced up.	▶ Allow saw to warm up to $+10^{\circ}\text{C}$.
Engine idles erratically.	Carburetor is iced up.	▶ Allow saw to warm up to $+10^{\circ}\text{C}$.
Engine stops while idling	Carburetor is iced up.	▶ Allow saw to warm up to $+10^{\circ}\text{C}$.
Poor acceleration	The chain is over-tensioned.	▶ Tension the chain properly.
	Chain lubrication system is supplying insufficient chain oil.	▶ Do not use the chainsaw and contact your STIHL servicing dealer for assistance.
Saw chain does not rotate when throttle is opened.	The chain brake is engaged.	▶ Disengage the chain brake.
	The chain is over-tensioned.	▶ Tension the chain properly.
	Bar nose sprocket is blocked.	▶ Clean the bar nose sprocket with STIHL resin solvent.
Smoke or burning smell while cutting.	Chain is not properly sharpened.	▶ Sharpen the chain properly.
	Insufficient chain oil in the tank.	▶ Fill up with chain oil.
	Chain lubrication system is supplying insufficient chain oil.	▶ Do not use the chainsaw and contact your STIHL servicing dealer for assistance.
	The chain is over-tensioned.	▶ Tension the chain properly.
	Chainsaw is not being used properly.	▶ Have correct use explained, then practice.

18.2 Standard Setting

- ▶ Shut off the engine and engage the chain brake.

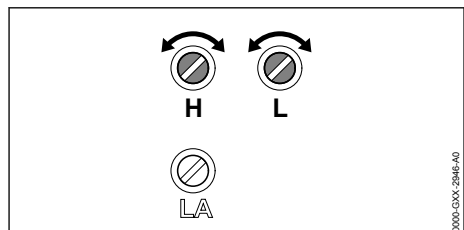

- ▶ Turn the high speed screw (H) counterclockwise as far as stop.

- ▶ Turn the low speed screw (L) clockwise as far as stop.
- ▶ Rotate the low speed screw (L) a quarter turn counterclockwise.

18.3 Adjusting Idle Speed

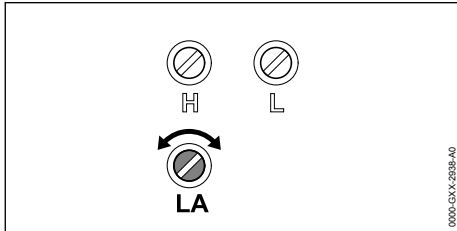

Engine stops while idling

- ▶ Carry out the standard setting.
- ▶ Start the engine and disengage the chain brake.
- ▶ Warm up the engine by opening and closing the throttle for about 1 minute.
- ▶ If the engine continues to stop while idling: Turn the idle speed screw (LA) half a turn clockwise and restart the engine.
- ▶ Turn the idle speed screw (LA) clockwise until the chain begins to run.
- ▶ Turn the idle speed screw (LA) one full turn counterclockwise.

Saw chain runs continuously while engine is idling

- ▶ Carry out the standard setting.
- ▶ Start the engine and disengage the chain brake.
- ▶ Warm up the engine by opening and closing the throttle for about 1 minute.
- ▶ Turn the idle speed screw (LA) counterclockwise until the saw chain stops running.
- ▶ Turn the idle speed screw (LA) one full turn counterclockwise.

18.4 Clearing the Combustion Chamber

- ▶ Engage the chain brake.

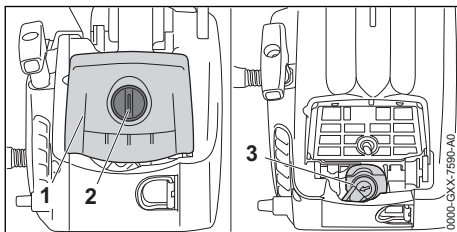

- ▶ Rotate the shroud lock (2) a half turn counterclockwise.
- ▶ Remove the shroud (1).
- ▶ Pull off the spark plug boot (3).
- ▶ Unscrew the spark plug.
- ▶ Dry the spark plug.



WARNING

- Unconfined sparks may occur if the starter grip is pulled after the spark plug boot has been removed. Sparks may cause a fire or an explosion in an easily combustible or explosive environment. This can result in serious or fatal injuries and damage to property.
 - ▶ Move the Master Control lever to position  and hold it there before pulling the starter grip.
- ▶ Move the Master Control lever to position and hold it there.
- ▶ Pull the starter grip and guide it back several times. The combustion chamber is cleared.
- ▶ Insert and tighten down the spark plug.

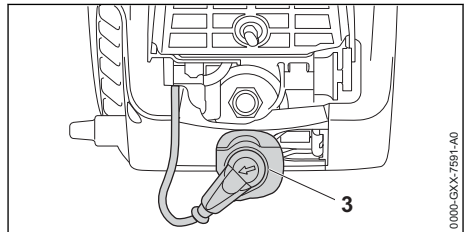

- ▶ Press the spark plug boot (3) firmly home.
- ▶ Place the shroud (1) in position.
- ▶ Rotate the shroud lock (2) clockwise until you hear a click. The shroud lock (2) is secure.

19 Specifications

19.1 STIHL MS 194 T Chainsaw

- Displacement: 31.8 cm³
- Engine power to ISO 7293: 1.4 kW (1.9 bhp)
- Idle speed to ISO 11681: 3,000 ± 50 rpm
- Approved spark plug: NGK CMR6H from STIHL
- Electrode gap: 0.5 mm
- Dry weight without guide bar and chain 3.3 kg
- Max. fuel tank capacity: 270 cc (0.27 l)
- Max. oil tank capacity: 220 cc (0.22 l)

19.2 Chain Sprockets and Chain Speeds

The following chain sprockets may be used:

- 6-tooth for 3/8" P
 - Maximum chain speed according to ISO 11681: 26.0 m/s
 - Chain speed at maximum power: 18.6 m/s
- 8-Tooth for 1/4" P
 - Maximum chain speed according to ISO 11681: 23.6 m/s
 - Chain speed at maximum power: 16.9 m/s

19.3 Minimum Groove Depth of Guide Bars

The minimum groove depth depends on the pitch of the guide bar.

- 3/8" P: 5 mm
- 1/4" P: 4 mm

19.4 Sound Values and Vibration Values

- Sound pressure level L_{pA} measured according to ISO 22868: 100 dB(A). The K value for the sound pressure level is 2 dB(A).
- Sound power level L_{WA} measured according to ISO 22868: 112 dB(A). K-value (uncertainty) for sound power level is 2 dB(A).
- Vibration level a_{HV} measured according to ISO 22867:

- Handlebar: 3.6 m/s². The K value for the vibration level is 2 m/s².
- Control handle: 3.6 m/s². The K value for the vibration level is 2 m/s².

For information on compliance with Employers' Vibration Directive 2002/44/EC see www.stihl.com/vib.

19.5 REACH

REACH is an EC regulation and stands for the Registration, Evaluation, Authorisation and Restriction of Chemical substances.

For information on compliance with the REACH regulation see www.stihl.com/reach.

19.6 Exhaust Emissions

The CO₂ value measured in the EU type approval procedure is specified at www.stihl.com/co2 in the product-specific technical data.

The measured CO₂ value was determined on a representative engine in accordance with a standardised test procedure under laboratory conditions and does not represent either an explicit or implied guarantee of the performance of a specific engine.

The applicable exhaust emission requirements are fulfilled by the intended usage and maintenance described in this instruction manual. The type approval expires if the engine is modified in any way.

20 Bar and Chain Combinations

20.1 STIHL MS 194 T Chainsaw

Pitch	Drive link gauge/groove width	Length	Guide bar	Number of teeth, sprocket nose	Number of drive links	Saw chain	
3/8" P	1.1 mm	25 cm	Rollomatic E light	7	39	61 PMM3 (3610)	
		30 cm	Rollomatic E, Rollomatic E light		44		
		35 cm	Rollomatic E, Rollomatic E light		44		
		40 cm	Rollomatic E		50		
		40 cm	Rollomatic E		55		
	1.3 mm	30 cm	Rollomatic E / Light 04	9	44	61 PMM3 (Type 3610) 61 PS3 Pro (3699)	
		35 cm			50		
		40 cm			55		
		30 cm	Rollomatic E, Rollomatic E light		9		63 PD3 (3612) 63 PM3 (3636) 63 PS3 (3616)
		35 cm			50		
40 cm	55						

Pitch	Drive link gauge/groove width	Length	Guide bar	Number of teeth, sprocket nose	Number of drive links	Saw chain
1/4" P	1.1 mm	25 cm	Rollomatic E	8	56	71 PM3 (3670)
		30 cm			64	
		35 cm			72	
		30 cm	Carving E	-	64	

The cutting length of a guide bar depends on the chainsaw and the saw chain being used. The actual cutting length of a guide bar may be less than the specified length.

21 Spare Parts and Accessories

21.1 Spare parts and accessories

STIHL These symbols indicate original STIHL spare parts and original STIHL accessories.

STIHL recommends the use of original STIHL spare parts and accessories.

Despite ongoing market observation, STIHL is unable to judge the reliability, safety and suitability of other manufacturers' spare parts and accessories; accordingly, STIHL cannot warrant for the use of those parts.

Original STIHL spare parts and original STIHL accessories are available from STIHL dealers.

22 Disposal

22.1 Disposing of Chainsaw

Contact the local authorities or your STIHL dealer for information on disposal.

Improper disposal can be harmful to health and pollute the environment.

- ▶ Take STIHL products including packaging to a suitable collection point for recycling in accordance with local regulations.
- ▶ Do not dispose with domestic waste.

23 EC Declaration of Conformity

23.1 STIHL MS 194 T Chainsaw

ANDREAS STIHL AG & Co. KG
Badstraße 115
D-71336 Waiblingen
Germany

declares under our sole responsibility that

- Category: chainsaw
- Manufacturer's brand: STIHL

- Model: MS 194 T
- serial number: 1137
- Displacement: 31.8 cm³

conforms to the relevant provisions of Directives 2011/65/EU, 2006/42/EC, 2014/30/EU and 2000/14/EC and has been developed and manufactured in compliance with the following standards in the versions valid on the date of production: EN ISO 11681-1, EN 55012 and EN 61000-6-1.

The EC type examination pursuant to Directive 2006/42/EC Art. 12.3(b) was carried out by DPLF, Deutsche Prüf- und Zertifizierungsstelle für Land- und Forsttechnik GbR (NB 0363), Spremberger Straße 1, 64823 Groß-Umstadt, Germany

- Certification number K-EG 2018/8641

The measured and guaranteed sound power levels were determined according to Directive 2000/14/EC, Annex V, using the ISO 9207 standard.

- Measured sound power level: 112 dB(A)
- Guaranteed sound power level: 114 dB(A)

The technical documents are stored at ANDREAS STIHL AG & Co. KG Produktzulassung.

The year of manufacture and serial number are indicated on the chainsaw.

Waiblingen, 2022-08-01

ANDREAS STIHL AG & Co. KG

pp 

Robert Olma, Vice President, Regulatory Affairs & Global Governmental Relations

24 UKCA Declaration of Conformity

24.1 STIHL MS 194 T Chainsaw



ANDREAS STIHL AG & Co. KG
 Badstraße 115
 D-71336 Waiblingen
 Germany

declares under our sole responsibility that

- Category: chainsaw
- Manufacturer's brand: STIHL
- Model: MS 194 T
- serial number: 1137
- Displacement: 31.8 cm³

conforms to the relevant provisions of UK regulations The Restriction of the Use of Certain Hazardous Substances in Electrical and Electronic Equipment Regulations 2012, Supply of Machinery (Safety) Regulations 2008, Electromagnetic Compatibility Regulations 2016 and Noise Emission in the Environment by Equipment for use Outdoors Regulations 2001 and has been manufactured in compliance with the following standards in the versions valid on the date of production: EN ISO 11681-1, EN 55012 and EN 61000-6-1.

The type examination was carried out by: Intertek Testing & Certification Ltd, Academy Place, 1-9 Brook Street, Brentwood, Essex, CM14 5NQ, United Kingdom

- Certification number: UK-MCR-0023

The measured and guaranteed sound power levels have been determined in accordance with the UK regulation Noise Emission in the Environment by Equipment for use Outdoors Regulations 2001, Annex 8, using the ISO 9207 standard.

- Measured sound power level: 112 dB(A)
- Guaranteed sound power level: 114 dB(A)

The technical documents are stored at ANDREAS STIHL AG & Co. KG.

The year of manufacture and serial number are indicated on the chainsaw.

Waiblingen, 2022-08-01

ANDREAS STIHL AG & Co. KG

pp

Robert Olma, Vice President, Regulatory Affairs & Global Governmental Relations

www.stihl.com



0458-568-0121-C



0458-568-0121-C